

MODIFICATION #2  
WEST LILAC ROAD OVER I-15 BRIDGE  
DEPARTMENT OF PUBLIC WORKS

**Request for a  
Modification to a Road Standard  
and/or to Project Conditions**

Project Number: TM 5571/5572 Date of Request: Sep. 12, 2012

Project Location: Interstate 15 and W. Lilac Road in the County of San Diego, State of California.  
127-072-20, 127-072-14 127-072-38, 127-072-41 127-072-40,

Thos. Bros. Map/Grid: 1049, 1069 APN: 127-072-46 127-072-47, 128-280-42 128-440-01, 128-280-46  
128-280-27, 128-280-10, 128-440-23, 128-280-37 128-440-05

Requestor Name: Accretive Investments, Inc Telephone: (858) 546-0700

Address: 12275 El Camino Real, Suite 110, San Diego, CA 92130

**Requested Modification (attach engineering sketches showing existing layout, details and notes):**

The standard road section for Light Collector Road 2.2C is 40'-54' wide curb to curb  
width on 64'-78' r/w with a minimum design speed of 40 mph. The requested modification  
to the road standard is to require no widening of the existing 40' wide West lilac Road  
bridge over I-15 and allow only re-striping and the addition of curb, gutter and sidewalk  
on one side of the road (see attachment 1).

**Reason for requested Modification (provide attachment if additional space is required):** \_\_\_\_\_

The existing 40' wide bridge section has a 24' travel way with 8' shoulders on each  
side. A proposed widening of the bridge would be extremely expensive, extremely  
disruptive to anyone that uses West Lilac Road & I-15, and would alter the beauty and  
historic nature of the bridge (see attachment 2). The modified road would also allow  
for safer pedestrian traffic over the bridge.

List alternatives that could mitigate the requested Modification (attach engineering sketches showing proposed layouts, details and notes): No alternative is proposed.

Describe the hardship(s) to the property owner(s) and/or neighbor(s) if the request is not approved (see note 3. on reverse): \_\_\_\_\_

Aside from the cost, widening a bridge of this type would be immediately met with strong  
opposition from preservationists, environmentalists, et al.

Provide Design and Cost Estimate for meeting the Condition (see note 3. on reverse): \_\_\_\_\_

Cost estimate for new bridge spanning I-15 is \$?????? (need second opinion)

See reverse for directions and important information.

# ATTACHMENT 1

## LILAC HILLS RANCH: 2.2C LIGHT COLLECTOR MODIFICATION TO ROAD STANDARDS

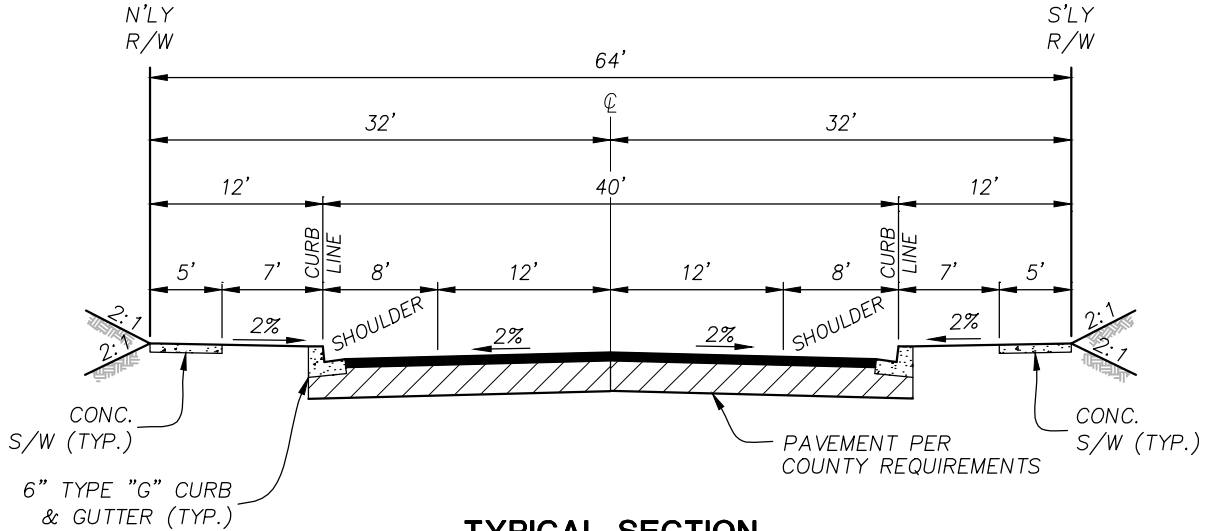

**TYPICAL SECTION  
2.2C LIGHT COLLECTOR**

NO SCALE  
(PUBLIC)

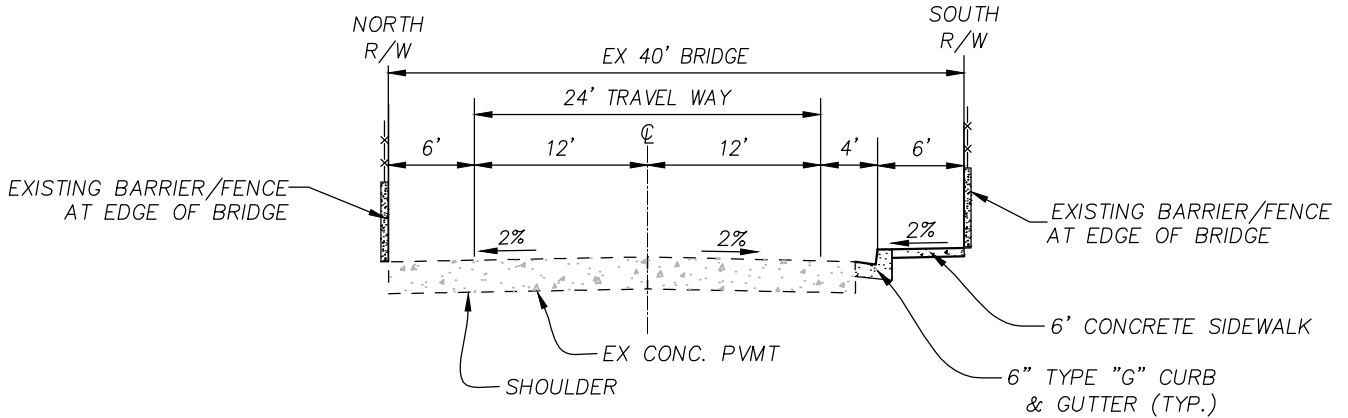

**PROPOSED TYPICAL SECTION  
(2.2C LIGHT COLLECTOR)  
WEST LILAC RD OVER I-15 BRIDGE**

NO SCALE  
(PUBLIC)



**ATTACHMENT 2**  
**LILAC HILLS RANCH: LIGHT COLLECTOR 2.2C**  
**MODIFICATION TO ROAD STANDARDS**

