



County of San Diego

Department of Environmental Health & Quality
Land and Water Quality Division

www.sdcdeh.org

ONSITE WASTEWATER SYSTEM GROUNDWATER SEPARATION POLICY

This document is only for determining potential groundwater levels and should be read together with the County's "On-site Wastewater Systems (Septic Systems): Permitting Process and Design Criteria".

The purpose of this policy is to:

- Protect the groundwater quality by ensuring proper treatment of the sewage effluent prior to its entering into the groundwater.
- Protect the public health from failing on-site wastewater systems caused by high groundwater.
- Provide a methodology for the evaluation of potential building sites using on-site wastewater systems with regards to maintaining minimum groundwater separation requirements with the use of an on-site wastewater system.

Definitions:

Any subsurface sewage disposal system, including graywater systems, septic systems, and alternative/experimental private sewage disposal systems are referred to as **onsite wastewater systems (OSWS)** by definition for this guideline.

For this Department's purposes, groundwater is defined as the water occupying all voids within a geologic stratum. Groundwater, therefore, includes any saturated zone that could affect the functioning of an OSWS. Transient high groundwater can occur during periods of heavy rainfall and can be identified by "spikes" in groundwater elevations observed in groundwater test borings for short periods of time.

Normal rainfall is defined as the average rainfall over the rainfall record considered representative of the area. The historical rainfall records kept by the County of San Diego Department of Public Works and records kept by NOAA are considered a resource for such information.

Background:

The Department of Environmental Health & Quality (DEHQ) enforces the Regional Water Quality Control Board (RWQCB), Region 9 requirements of maintaining at least a five-foot separation between the bottom of the OSWS disposal point and the highest anticipated groundwater level. Projects within the Colorado Regional Water Quality Control Board, Region 7, located east of the coastal mountains (desert), are subject to greater separation requirements, due to the extreme permeability and transmissibility of some desert basin soils.

Groundwater typically fluctuates seasonally depending on local geology and rainfall amounts. In certain areas dependent on imported water and OSWS, DEHQ has observed rising groundwater levels. Groundwater levels fall in response to drought and well extraction, and rise in response to rainfall and in some cases, increased irrigation, agriculture and residential development. DEHQ has observed fluctuations in groundwater elevations from a few inches to greater than twenty feet. Major fluctuations have been observed in areas such as the Ramona and Valley Center basins.

OSWS failures due to high groundwater result in sewage effluent backing up into homes and surfacing on the ground creating public health hazards, and can contribute to the contamination of potable groundwater resources.

As a result of above normal rainfall periods in the late 1970's and early 1980's, DEHQ experienced situations where previously approved lots were observed to have high groundwater impacting the proposed or existing OSWS. In 1980 a groundwater policy was written requiring that the determination of actual or potential groundwater levels be verified prior to issuing septic tank permits. The policy required that specific depths of test holes be used based on the season and also specified that the presence or absence of groundwater in these holes would be adequate to determine if a septic tank permit could be issued.

Since 1980, the County has seen several wide fluctuations in the quantity of rainfall. Over periods of time, there have been drought cycles followed by cycles of normal to above normal rainfall. During periods of normal or above normal rainfall, the 1980 groundwater policy was generally sufficient to determine if high groundwater was a concern prior to issuing a septic tank permit. Experience has shown that there are instances where the absence of groundwater in a ten, fifteen or even twenty foot deep observation boring on a lot does not guarantee that groundwater will not rise to within five feet from the bottom of the proposed OSWS during periods of normal or above normal rainfall. In some cases, the only certain way to determine depth to high groundwater on a site is to observe the groundwater depth during or immediately after a normal average rainfall season. ***If groundwater has been documented to rise to a level that would violate the requirements of the RWQCB, a permit for the OSWS will not be issued.***

1. Procedure For Groundwater Determination For Discretionary Projects:

Subdivisions, parcel maps, boundary adjustments, certificates of compliance and percolation tests are all projects that require that DEHQ certify that each lot can support an OSWS that will not violate the RWQCB mandates. To meet this requirement, test borings and/or observation wells for monitoring groundwater in conformance with this policy shall be installed. Maps showing the location of the borings and their logs shall be submitted to DEHQ. The project engineer, geologist or environmental health specialist (registered professional) must determine the actual and potential high groundwater levels in the area of the proposed OSWS at the time of submittal for review by DEHQ.

The registered professional, must support their expressed conclusion it is unlikely that seeps or springs would develop as a results of the OSWS and the high historic groundwater elevation will not encroach upon the 5-foot minimum separation required between the bottom of the proposed OSWS and the highest anticipated groundwater level.

Transient high groundwater conditions (spikes) must be documented thoroughly if encountered. A written discussion by the registered professional must be submitted to DEHQ along with groundwater monitoring log(s) for review and concurrence. The discovery of groundwater spikes on a lot will be evaluated on a case-by-case basis.

DEHQ and/or the RWQCB may require a comprehensive hydro-geologic study. This study shall include but not be limited to; data such as rainfall, total imported water use, projected water use, surface drainage, geologic formations, depth of water table and other relevant data as determined by the registered professional.

2. Existing Lot OSWS Design Review:

- a) If this site review reveals any evidence of groundwater changes, including but not limited to; plant growth, ponding water, or OSWS failures in the area, additional groundwater test borings may be required. DEHQ staff will specify the depth and the locations of the additional test borings in consultation with project registered professional.
- b) When groundwater is observed in the borings and DEHQ has reason to believe that groundwater could rise to an unacceptable level during the course of a normal rainfall season, monitoring may be required to determine that groundwater will not rise to the highest historic groundwater elevation which will not encroach upon the 5-foot minimum separation between the bottom of the proposed OSWS. Monitoring, if required, must be conducted during the course of an average annual rainfall year and/or when full groundwater recharge has occurred.
- c) When groundwater is not observed in the boring but there is evidence of past high groundwater levels, such as documentation of groundwater rise on adjacent properties, monitoring may be required. Experience has shown that there are instances where the absence of groundwater in a ten, fifteen or even twenty foot deep observation boring on a lot does not guarantee that groundwater will not rise to within five feet from the bottom of the proposed OSWS during periods of normal or above normal rainfall. In some cases, the only certain way to determine depth to high groundwater on a site is to observe the groundwater depth during the course of an average annual rainfall year and/or when full groundwater recharge has occurred.
- d) If there is a dry boring, there is not a known history of rising groundwater and there is no evidence of groundwater changes, including but not limited to; plant growth, ponding water, or OSWS failures in the area the project will be able to move forward.
- e) The registered professional conducting the groundwater study must support their express conclusion it is unlikely that seeps or springs would develop as a result of the OSWS and the highest historic groundwater elevation will not encroach upon the 5-foot minimum separation between the bottom of the proposed OSWS. The supporting data shall include, but not be limited to, data on the sites topography, soils, geology, basin studies, hydro-geologic studies, and groundwater-monitoring data from the on-site observation wells through a normal rainfall year.

3. Testing procedures for groundwater shall consist of the following:

- a) Test borings in the area of an OSWS shall extend to a minimum of 15 feet unless refusal is reached. Deeper depths may be required depending on site-specific conditions as determined by DEHQ or the project engineer. Site-specific conditions may include, but not be limited to; the proposed depth of the system, local geology, soil types encountered, elevation and terrain, features on site, evidence and/or knowledge of historic ground water levels in the area, and the anticipated fluctuation of the groundwater table in times of normal to above normal annual rainfall.
- b) Test borings in the area of a seepage pit and/or horizontal pit systems shall extend to at least 10 feet deeper than the bottom of the proposed pit.
- c) Since groundwater does not always immediately flow into a test boring, DEHQ requires a minimum of 72 hours pass before an accurate groundwater measurement is taken. The registered professional and/or the property owner maintain full responsibility for protecting the public from any hazards related to the test borings. It is recommended that all test borings that encounter groundwater be converted to observation wells so the groundwater conditions can be monitored over time. The observation wells must meet the minimum construction requirements outlined on the figure below:

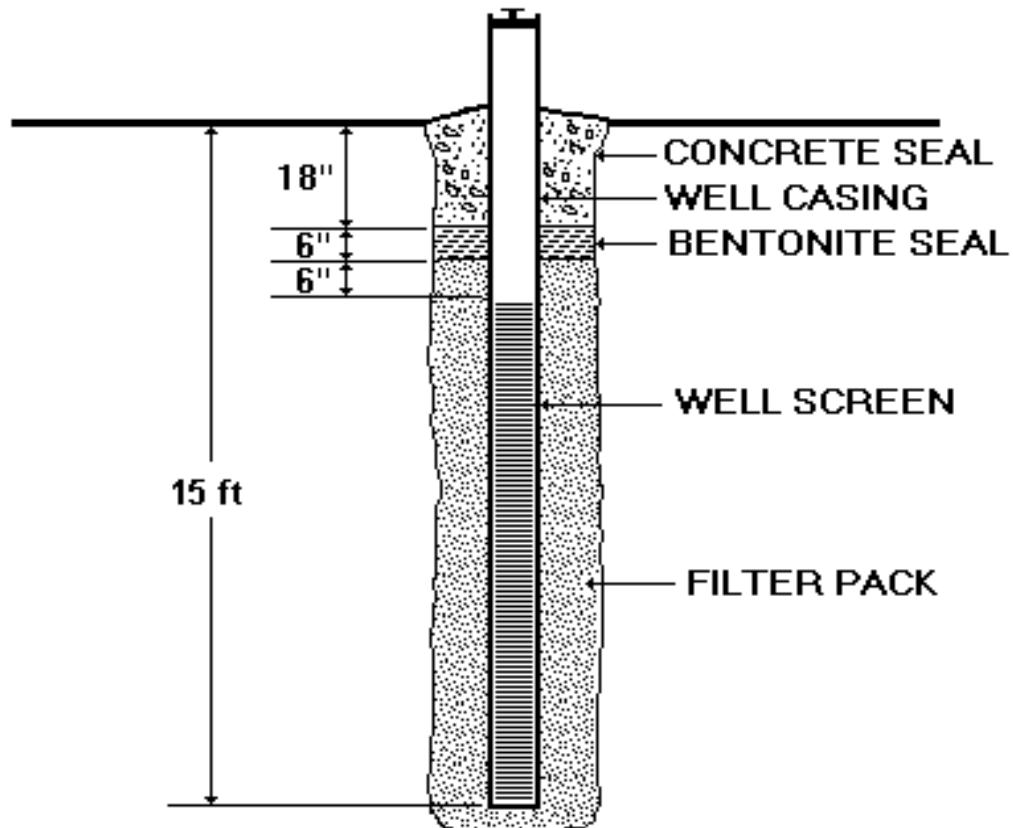

TYPICAL OBSERVATION WELL FOR GROUNDWATER MONITORING

- d) If the registered professional does not wish to complete the test borings as observation wells they can cover the test boring, place safeguards around the

borings to prevent unauthorized access and make an appointment for DEHQ staff to observe the boring at least 72-hours after the boring has been completed.

- e) During periods of below normal average rainfall, or after periods of drought where there has not yet been sufficient ground water recharge, the absence of groundwater in test borings in areas where groundwater is suspect may not mean that approval to issue a septic tank permit can be granted. Experience has shown that there are instances where the absence of groundwater in a ten, fifteen or even twenty foot deep observation boring on a lot does not guarantee that groundwater will not rise to within five feet from the bottom of the proposed OSWS during periods of normal or above normal rainfall. It may be necessary for DEHQ to monitor the test borings for a sufficient period of time to determine where groundwater will rise to during normal to above normal rainfall.

The County is now exploring how alternative types of OSWS known as Onsite Sewage Treatment Systems (OSTS) might be used in circumstances where a five-foot separation from ground water cannot be demonstrated. Pursuant to Water Code section 13291, the state is also developing further regulations that will apply to OSWS statewide. These anticipated state regulations may not be in place until 2008 or later. No completion date can be estimated yet for the County's review of alternative OSWS/ OSTs. However, changes in this regulatory program may require review under CEQA, and will require coordination with the San Diego RWQCB.

Note: This policy supersedes the January 17, 1980 groundwater policy.