



COUNTY OF SAN DIEGO
HEALTH AND HUMAN SERVICES AGENCY



LIVE WELL
SAN DIEGO

Public Health Services

Specimen Collection and Submission Manual



Public Health Laboratory

May 2026

Public Health Laboratory Contact Information

Address: 5540 Overland Ave, San Diego, CA 92123

Phone: (858) 325-6400

Fax: (858) 268-4102

Hours of Operation: Monday - Friday 8:00 a.m. – 5:00 p.m.

Hours of Specimen Drop Off: Monday - Friday 8:00 a.m. - 4:30 p.m

Accreditations

Public Health Laboratory: CLIA # 05D2324555

State of California License: 1238

Federal Tax ID Number: 956000934

Medicare Number: 05L0009312

Medi-Cal Provider Number: LAB60808F

National Provider Number:1144357948

Preface

The County of San Diego Public Health Laboratory (SDPHL) mission is to protect the health of the community, prevent the spread of diseases, and facilitate a prompt and well-coordinated response to emerging health threats. SDPHL provides reference and diagnostic laboratory services in Bacteriology, Mycobacteriology, Water Bacteriology, Food Bacteriology, Parasitology, Virology, and Serology. SDPHL is also involved in the investigation of disease outbreaks, including possible bioterrorism activities.

Our goal is to reduce morbidity and mortality by providing accurate, precise, and timely results that support Public Health programs, the Health and Human Services Agency, other *LiveWell* agencies and the medical and laboratory community of the County of San Diego.

Specimen collection is a critical initial step in laboratory diagnosis. Meaningful laboratory results require careful attention to the specimen source, the method of collection, the storage and transport, and timely delivery of the collected specimens. In addition, a completed test requisition with tentative diagnosis and relevant history is essential for optimal and efficient laboratory workup of the collected specimens.

This specimen collection and submission manual is designed to serve as a guide for physicians, nurses, and other allied health personnel in charge of ordering, selecting, and collecting specimens from patients. Should you need additional information, please contact SDPHL at (858) 325-6400 , or at phslaboratory.hhsa@sdcountry.ca.gov. The Public Health Laboratory is committed to providing excellent services to the healthcare and laboratory community.

Table of Contents

PART I: GENERAL INFORMATION

1. How to Use This Manual	6
2. Directory of Administrative and Supervisory Staff	6

PART II: GENERAL GUIDELINES

1. Specimen Collection	6
2. Test Requisition Forms	7
3. Specimen Labeling	7
4. Specimen Packaging and Shipping	8
5. Unacceptable Specimens	8
6. Receiving Test Results from the Public Health Laboratory	
7. Send-out and Referral Specimens	9
8. Suspected Chemical or Biological Terrorism Samples	9
9. Water and Food Samples	10

PART III: CLINICAL SPECIMEN TEST CATALOG

1. Suspected Agents of Bioterrorism from Sentinel Laboratories	11
2. Suspected Agents: Ricin Toxin / Environmental Swab	13
3. AFB Smear with Mycobacteria Culture and Susceptibility	15
4. Candida auris Colonization Screening	18
5. Carbapenemase Gene Detection	21
6. Chlamydia Trachomatis & Neisseria Gonorrhoeae NAAT	24
7. E. coli Confirmation, Serotyping & Shiga Toxin Detection	26
8. Enteric Pathogen Culture – Primary Specimen	28
10. Hepatitis A PCR	31
11. Hepatitis B Reflex Panel	33
12. Hepatitis C Antibody Reflex Panel	35
13. HIV-1 / HIV-2 Confirmatory Test	39
14. HIV-1/2 Ag/Ab Reflex Panel	40
15. HIV-1 Viral Load	41
16. Herpes Simplex Virus (HSV 1/2) NAAT	36
17. Influenza PCR and Subtyping	44
18. Measles PCR	47
19. MPOX PCR	49
19. Mumps PCR	51
20. Mycobacterium – Primary Drug Susceptibility Testing	53
21. MTBC/Rifampin Susceptibility PCR	55
22. Neisseria gonorrhoeae Antibiotic Susceptibility Testing	57
23. Neisseria gonorrhoeae Culture – Primary Specimen	60
24. Norovirus PCR	63
25. Plasmodium spp., Babesia & Other Blood Parasites	65
26. QuantiFERON TB-Gold Plus	67
27. Respiratory 4-Plex (Influenza A/B, SARS-CoV2, RSV)	69

26. Salmonella & Shigella Culture/PCR – Primary Specimen	71
27. Salmonella Identification and Serogrouping	73
28. Shiga Toxins EIA & STEC Isolation	75
29. Shigella Identification and Serogrouping	77
30. STEC Isolation from Enrichment Broth	79
31. Syphilis Reverse Algorithm	81
32. Trichomonas vaginalis PCR	83
33. Vibrio cholerae Identification	85
34. Vibrio, Aeromonas & Related Organisms	87
35. Yersinia (non-Y. pestis) & Other Enterobacterales	89
PART IV: APPENDICES	
Appendix 1: Packaging and Labeling Instructions	91
Appendix 2: Directions to SDPHL Specimen Receiving	93
Appendix 3: Clinical Test Requisition Form	94
Appendix 4: Client Agreement Form	95

I. GENERAL INFORMATION

How to Use This Manual

Consult the Table of Contents to locate information on available tests performed at SDPHL. Each test will provide a detailed description of the test, test method, the types of specimens required, the storage and transportation conditions, the clinical significance of the test, and the turnaround time for the test.

How to Obtain Specimen Collection Materials and Forms:

Available specimen mailers and forms may be requested by phone, fax, or email. Supplies can be picked up from specimen receiving one day after the request is submitted. Supplies can also be mailed upon request.

Additional lab supplies are available to the Public Health Services (PHS) clinics and County healthcare facilities. Supplies can be requested by completing a [Laboratory Supplies Form](#) indicating the quantity of each item needed, then faxing the request to (858) 268-4102. The most updated supply order form can be found at the [SDPHL home page](#).

**Submission of specimens to SDPHL requires the submitter to first complete a [Client Agreement Form](#) found at the [SDPHL home page](#) under [Laboratory Forms](#) section.

Once the form is complete, please email the form to Labs.HHSA@sdcounty.ca.gov for approval. Once the submitter is approved, a team member from our business operations team will notify the submitter. Please allow for 24 hours for processing. This process needs to be done once before the initial submission of specimen to SDPHL and then annually or if information needs to be updated.

II. GENERAL GUIDELINES

A. Specimen Collection

1. Adhere to standard precautions when handling blood and body fluid specimens.
2. Obtain specimens prior to administering antimicrobial therapy.
3. Use sterile equipment and aseptic techniques for collecting specimens.
4. Obtain an appropriate specimen representative of the diseased site and avoid contamination of the specimen with microbial flora.
5. Collect specimen during the acute phase of the disease.
6. Collect an adequate quantity of specimen to permit complete testing.
7. Collect specimens in appropriate sturdy, leak-proof, screw-cap specimen containers, screw-cap transport tubes or appropriate blood collection tubes.
8. Take care not to contaminate the outside surfaces of the specimen containers with the specimen.
9. Screw-cap specimen containers are to be sealed tightly to avoid leakage.

B. Test Requisition Forms

The most updated test requisition form can be found at [SDPHL home page](#).

Specimen Collection and Submission Manual

All specimens must be accompanied by a completed test requisition form. Submit one test requisition form per specimen source. **All mandatory (*) fields should be completed for the sample to be accepted by SDPHL.** Providing additional patient information is helpful for viral and parasitology specimens, including malaria. Travel history and symptom details are often valuable for accurate and timely interpretation.

Test requisition form has 3 sections:

1. Patient and Submitter Information

- a. Patient name, patient address, identification number, date of birth, gender, pregnancy status, ethnicity, race and extended ethnicity and race (if available).
- b. First and Last Name, National Provider ID (NPI) and phone number of the ordering physician. **Note:** Use this [link](#) to search for your physician NPI.
- c. The submitter's facility name and address.
- d. Facility secure email address (if available) and phone number
- e. Alternate contact information, name and phone number of the person responsible for answering questions about specimen.
- f. Clinical Information: Provide pertinent history (if available)
 - i. In the case of zoonoses and unusual pathogens, include history of travel, exposure, risk factors or occupation of patient.
 - ii. In the case of foodborne illnesses, include symptoms, incubation period and type of food implicated.
 - iii. Any other relevant information that could affect the outcome of the test.

2. Specimen Information

- a. Source of specimen
- b. Date of specimen collection

3. Requested Test

C. Specimen Labeling

1. The submitter is responsible for correct labeling of submitted specimens. All specimens **must** be clearly identified with:
 - a. Patient name (last name and complete first name) and a unique patient identifier (UPI), when available. Examples of a unique patient identifier: the HIV antibody confidential form number, Detention facility booking number or hospital medical record number. De-identified or confidential testing can be submitted with just a UPI, patient date of birth, and date of specimen collection.
 - b. For viral load requests, the date of specimen collection and time of collection is required.
 - c. Specimen source or body site, as appropriate.
2. All specimens must be accompanied by a completed test requisition form.

Specimen Collection and Submission Manual

D. Specimen Packaging and Shipping

1. Package specimens according to federal regulations for [USPS](#), [IATA](#) and [DOT](#). Consult with your agency's biosafety coordinator or SDPHL for guidance. Please refer to Appendix 1 for examples.
2. Clinical samples are divided into three categories – Infectious Substance Category A, Biological Substance Category B, and Exempt. The definitions for these three categories can be found in the IATA Dangerous Goods Regulations (IATA 1.0) and the Code of Federal Regulations (49 CFR 100-200). A brief description is as follows:
 - a. Biological Substance – Category A (UN 2814)
Category A substance (pathogen or agent) is one that is capable of causing permanent disability, life-threatening or fatal disease in otherwise healthy humans (UN2814) or animals (UN2900). Packaging rules for Category A substances are more stringent.
 - b. Biological Substance – Category B (UN 3373)
The majority of specimens will qualify as Category B, which are classified as substances which do not meet the criteria for inclusion in Category A. Category B is generally applicable for all clinical samples that are being shipped by common carrier for diagnostic purposes.
Typical examples include:
 - Clinical or patient specimens (blood, body fluids, excreta, secretions, swabs, blood, tissue)
 - Typical laboratory cultures of routinely encountered non-Category A microorganisms
 - c. Exempt - Samples known not to contain any agent capable of infecting humans or animals.
3. Transport specimens promptly to the laboratory at the appropriate temperature for the test being requested.
4. Use of County mail is not acceptable, since delivery often requires several days and the specimens may deteriorate before arrival.
5. The SDPHL supplies limited courier service for certain specimens. Please call (858) 325-6400 for guidance.
6. Submit specimens to the SDPHL, during normal working hours of 8 a.m. to 4:30 p.m., Monday through Friday. SDPHL is closed after-hours, weekends, and County observed holidays. If a specimen needs to be delivered after hours, contact SDPHL **in advance** to make special arrangements.

Note: Specimens arriving in a box/container by a courier may be rejected if it is not properly labeled and addressed to SDPHL on the outside of the box/container.

E. Unacceptable Specimens

A list of criteria below for specimens that are lacking the proper identification or quality and can be rejected upon receipt:

1. Specimens lacking proper identification.
 - a. It must be labelled with at least 2 of the following patient identifiers:
 - i. First Name and Last Name

- ii. Date of Birth
 - iii. Unique identifier
2. Specimens labeled with information that does not match information on the test request form.
 3. Specimen containers that are broken, leaking, or have evidence of contamination on outer surfaces or on the request form.
 4. Specimens exceeding temperature or transport requirements for the specimen.
 5. Specimens and requisition which are incompatible (i.e. urine specimen with requisition checked off for sputum).
 6. Specimens received with no test requisition form. (The PHL will attempt contact the submitter to retrieve the missing test requisition.).
 7. Hemolyzed or clotted blood specimens.

Notes:

- Samples will be considered unsatisfactory after a week if SDPHL does not receive all mandatory info for the test requisition.
- Cultures should not be submitted in Petri dishes (except for gonorrhea cultures submitted by the STD clinic at the Rosecrans location).

F. Receiving Test Results from the Public Health Laboratory

Any release by the laboratory of results or protected personal health information -must comply with regulations under the Health Insurance Portability and Accountability Act of 1996 (HIPAA). By submitting samples for testing to the Public Health Laboratory the submitter agrees to accept and follow the Public Health Laboratory's reporting policies and HIPAA requirements.

Results will be sent to the responsible individual per the submitter's SDPHL's Client Fax Agreement Form, which can be found the [SDPHL's Home Page](#) under the Laboratory Forms section. Results may also be sent to a pre-approved secure email.

G. Send-out and Referral Specimens

Referral testing through the California Department of Public Health (CDPH) or the Centers for Disease Control and Prevention (CDC) is available for certain bacterial, fungal, mycotic or viral diseases. Tests performed at CDPH and CDC may need pre- approval by the Epidemiology Program and either CDPH or CDC.

- [CDPH Microbial Diseases Laboratory \(MDL\) Services and Test Catalog](#)
- [CDPH Viral and Rickettsial Diseases Laboratory \(VRDL\) Services and Test Catalog](#)
- [CDC Test Directory](#)

For more information about send-outs please contact SDPHL at (858) 325-6400 or email phslaboratory.hhsa@sdcountry.ca.gov.

1. Suspected Chemical or Biological Terrorism samples:

Call SDPHL for instructions for the following organisms:

- *Bacillus anthracis*
- *Francisella tularensis*
- *Brucella sp.*
- *Yersinia pestis*

- *Burkholderia pseudomallei*
- *Burkholderia mallei*
- Ricin toxin

J. Food Samples

Testing can be performed on food products that may be suspected of causing a foodborne outbreak. For more information on how to properly collect water and food samples, please call the San Diego County Department of Environmental Health and Quality (DEHQ) for guidance and instructions at 800-253-9933. To submit samples, please call SDPHL at (858) 325-6400 for more information.



San Diego County Public Health Laboratory

Jeremy Corrigan, DrPH, HCLD/TS(ABB)
 5540 Overland Ave., San Diego, CA 92123
 Ph: 858-325-6400
 Fax: 858-268-4102



**LIVE WELL
 SAN DIEGO**

Suspected Agents of Bioterrorism from Sentinel Laboratories

Bacillus anthracis, Francisella tularensis, Brucella sp., Yersinia pestis, Burkholderia pseudomallei, Burkholderia mallei

TEST INFORMATION	INFORMATION DETAILS
Is this test currently being performed?	Yes
Pre-Approval	Yes
Supplemental Information Requested	<ul style="list-style-type: none"> Travel History Illness Onset Date Results of Biochemicals Performed
Submittal Form	Specimens must be accompanied with a hard copy of the completed SDPHL Test Requisition (PDF).
Methodology	Nucleic Acid Amplification Test following the Laboratory Response Network for bioterrorism protocols and culture identification using conventional biochemical methods.
Reflex Testing	No
Acceptable Specimen Type(s) and Collection Method	Isolated culture on Chocolate or SBA
Minimum Volume Requested	N/A
Transport Medium	Chocolate or Sheep's Blood Agar
Specimen Labeling	Each specimen must be labeled with at least two unique patient identifiers, e.g., patient full name and date of birth.
Storage & Preservation of Specimen / Shipping Conditions	Room temperature
Shipping Instructions	<p>Ship Category A (UN 2814): Isolated culture on Chocolate agar.</p> <p>Ship specimens and a hard copy of the completed submittal forms.</p>

Shipping Address	<p style="text-align: center;">San Diego Public Health Laboratory ATTN: Specimen Receiving 5540 Overland Ave. San Diego, CA 92123 Phone: 858-325-6400</p>
Turnaround Time	<p style="text-align: center;">Testing performed same day of receipt, otherwise determined on a case-by-case basis.</p>
Limitations	<p style="text-align: center;">N/A</p>
Additional Information	<p style="text-align: center;">N/A</p>
Contact Information	<p style="text-align: center;">phslaboratory.hhsa@sdcounty.ca.gov</p>



San Diego County Public Health Laboratory

Jeremy Corrigan, DrPH, HCLD/TS(ABB)
 5540 Overland Ave., San Diego, CA 92123
 Ph: 858-325-6400
 Fax: 858-268-4102



LIVE WELL
 SAN DIEGO

Suspected Agents: Ricin Toxin/Environmental Swab

TEST INFORMATION	INFORMATION DETAILS
Is this test currently being performed?	Yes
Pre-Approval	Yes
Supplemental Information Requested	Illness, Onset Date, Results of Biochemicals Performed (if applicable)
Submittal Form	Specimens must be accompanied with a hard copy of the completed SDPHL Test Requisition (PDF).
Methodology	Nucleic Acid Amplification Test following the Laboratory Response Network for bioterrorism protocols and culture identification using conventional biochemical methods, Time-Resolved Fluorescence Assay.
Reflex Testing	No
Acceptable Specimen Type(s) and Collection Method	Dry swab
Minimum Volume Requested	N/A
Specimen Labeling	Each specimen must be labeled with at least two unique patient identifiers, e.g., patient full name and date of birth.
Storage & Preservation of Specimen / Shipping Conditions	Room temperature
Shipping Instructions	Ship Category A (UN 2814): Isolated culture on Chocolate agar. Ship specimens and a hard copy of the completed submittal forms.

Shipping Address	<p style="text-align: center;">San Diego Public Health Laboratory ATTN: Specimen Receiving 5540 Overland Ave. San Diego, CA 92123 Phone: 858-325-6400</p>
Turnaround Time	<p style="text-align: center;">Testing performed same day of receipt, otherwise determined on a case-by-case basis.</p>
Limitations	<p style="text-align: center;">N/A</p>
Additional Information	<p style="text-align: center;">N/A</p>
Contact Information	<p style="text-align: center;">phslaboratory.hhsa@sdcounty.ca.gov</p>



San Diego County Public Health Laboratory

Jeremy Corrigan, DrPH, HCLD/TS(ABB)
 5540 Overland Ave., San Diego, CA 92123
 Ph: 858-325-6400
 Fax: 858-268-4102



LIVE WELL
 SAN DIEGO

**Acid Fast Bacillus (AFB) Smear with
 Mycobacteria Culture and Susceptibility
 CPT Code(s): 87206, 87116, 87188**

TEST INFORMATION	INFORMATION DETAILS
Is this test currently being performed?	Yes
Pre-Approval	No
Supplemental Information Requested	<ul style="list-style-type: none"> • Sample series # • Alternate contact for submitter • Date of onset/exposure • Travel history • Previous lab results • Symptoms • Therapy • Treatment outcome • Other relevant information
Submittal Form	Specimens must be accompanied with a hard copy of the completed SDPHL Test Requisition (PDF).
Methodology	Specimens decontamination and concentration is followed by a fluorochrome stain, and a MTB/RIF GeneXpert assay may be performed upon request on a smear negative sediment. Specimens are inoculated in mycobacterial growth indicator tube (MGIT) liquid-based assay. MTB/RIF Assay is automatically performed on the first AFB positive primary sediment from a patient and on <i>Mycobacterium sp.</i> isolates. Growth-based drug susceptibility testing (DST) is reflexively performed on the first positive MTBC cultures from a patient via broth-based method.
Reflex Testing	Growth-based susceptibility is reflexively performed on the first positive MTBC cultures from a patient (within the past 3 months) via broth-based method.

Acceptable Specimen Type(s) and Collection Method	<ul style="list-style-type: none"> • Sputum, expectorated or induced - minimum volume is 3 mL (5 mL max preferred). Do not pool multiple specimens. Multiple specimens on an individual patient must be collected at least 8 hours apart. • Gastric lavage fluid- 10 mL minimum • Urine - 10 mL minimum, 40 mL preferred • Stool - 1 gram minimum (no smear performed) • Tissue - submit in 2-3 mL of sterile saline 		
	<ul style="list-style-type: none"> • Body fluids - 10 mL minimum • Swab specimens from sterile or non-sterile sites. 		
Minimum Volume Requested	See above		
Specimen Labeling	Each specimen must be labeled with at least two unique patient identifiers, e.g., patient full name and date of birth.		
Storage & Preservation of Specimen / Shipping Conditions	All specimen types may be transported to the laboratory at room temperature within 1 hour of collection. If transport is delayed, specimen should be refrigerated 2-8°C (not frozen) and received in the lab within five (5) day of collection.		
Shipping Instructions	Ship specimens and a hard copy of the completed submittal forms.		
Shipping Address	<p style="text-align: center;">San Diego Public Health Laboratory ATTN: Specimen Receiving 5540 Overland Ave. San Diego, CA 92123 Phone: 858-325-6400</p>		
Turnaround Time	Method	Frequency	TAT
	Smears	Daily (M-F)	Same day when received by 9am M-Th; by 12 pm on Friday
	Cultures	Daily (M-F)	6-8 weeks or up to 10 weeks by request
	MTB/RIF Assay	As needed	1 business day
	DSTs	Twice a week	4-6 weeks

<p style="text-align: center;">Limitations</p>	<p>The following conditions will result in a specimen being rejected as unsatisfactory:</p> <ul style="list-style-type: none"> • Sputum specimens older than 5 days at time of processing. • Specimen leaked in transit. • Specimen has no name on the label. • Specimen is labeled with information that does not match the requisition form. • Outer surfaces of collection container are visibly contaminated. • Requisition form is visibly contaminated. • Specimen volume is less than 3 mL.
<p style="text-align: center;">Additional Information</p>	<p>If RIF resistance is detected, the isolate is sent to the California Department of Public Health (CDPH) for sequencing-based DST confirmation.</p>
<p style="text-align: center;">Contact Information</p>	<p style="text-align: center;">phslaboratory.hhsa@sdcounty.ca.gov</p>



San Diego County Public Health Laboratory

Jeremy Corrigan, DrPH, HCLD/TS(ABB)
 5540 Overland Ave., San Diego, CA 92123
 Ph: 858-325-6400
 Fax: 858-268-4102



LIVE WELL
 SAN DIEGO

Candida auris Colonization Screening

TEST INFORMATION	INFORMATION DETAILS
Is this test currently being performed?	Y
Pre-Approval	<p>Yes, must be approved by the San Diego County Epidemiology Healthcare-Associated Infections (HAI) program <i>prior</i> to submission.</p> <p>Please coordinate with phs.hai.hhsa@sdcounty.ca.gov to ensure proper submission.</p>
Supplemental Information Requested	N/A
Submittal Form	Submit specimens with a SDCPHL barcode label, which will generate a TRF upon receipt in the laboratory. If not using a barcode label, submit specimens with a hard copy of the completed SDCPHL Test Requisition Form (TRF).
Methodology	Real-Time PCR utilizing the BD MAX™ System for confirming <i>C.auris DNA</i> directly from patient specimens.
Reflex Testing	Culture-based testing will be attempted on specimens for which Positive or Indeterminate PCR results were obtained.
Acceptable Specimen Type(s) and Collection Method	Collect specimens by swabbing the patient's axilla and groin using the BD <i>ESwab</i> ® collection and transport system. <i>ESwab</i> Instructions at Copan <i>ESwab</i> instructions (PDF) .
Minimum Volume Requested	1.0mL (standard amount supplied with BD <i>ESwab</i> collection kit)
Transport Medium	BD <i>ESwab</i> with Amies Buffer included in the <i>ESwab</i> ® collection and transport system.
Specimen Labeling	<ol style="list-style-type: none"> 1. Each specimen must be labeled with at least two unique patient identifiers, including patient full name, and at least one other identifier (specimen accession number, date of birth, medical record number) 2. Collection date 3. SDCPHL barcode label

Storage & Preservation of Specimen / Shipping Conditions	Ship the specimen with cold pack to the laboratory for processing within 9 days of collection.
Specimen Stability	Room Temperature: not acceptable. Refrigerated: up to 4 days. Frozen: do not freeze.
Shipping Instructions	Transport to the lab with cold pack. Ship ESwab specimens with cold pack. Follow the appropriate DOT/IATA approved shipping procedures for a Biological Substance, Category B (UN3373).
Shipping Address	San Diego Public Health Laboratory ATTN: Specimen Receiving 5540 Overland Ave. San Diego, CA 92123 Phone: 858-325-6400
Turnaround Time	0-3 business days
Limitations	<ol style="list-style-type: none"> 1. This test is validated in-house for reporting under CLIA as a laboratory-developed test, but it is not FDA-approved. 2. This test cannot differentiate between viable and non-viable <i>Candida auris</i> microorganisms in the samples. 3. A negative result does not rule out patient colonization with <i>Candida auris</i> if the microorganism is present below the limit of detection (LOD) or if significant concentrations of inhibitory substances are present in the clinical specimen. 4. This test is intended for infection control purposes. Additional culture of swabs that are PCR-positive for <i>C. auris</i> will be performed for surveillance purposes only.
Rejection Criteria	<ol style="list-style-type: none"> 1. Samples with insufficient or conflicting labelling 2. Leaking samples 3. Specimens shipped without cold packs 4. Specimens received past 9 days from collection date 5. Specimen/sample types not meeting acceptance criteria
Additional Information	<ol style="list-style-type: none"> 1. Testing frequency is daily, on regular business days. 2. If any of the above criteria cannot be met, please contact the SDCPHL Bacteriology/Mycology/Parasitology Section, Monday-Friday, 8 AM to 5 PM PT, at 858-694-3992, or contact Paul Temprendola at 619-917-2144 for special considerations.

Contact Information

For questions about submissions, please contact the SDCPHL Bacteriology/Mycology/Parasitology section at 619-917-2144, 858-694-3992, or phslaboratory.hhsa@sdcounty.ca.gov



San Diego County Public Health Laboratory

Jeremy Corrigan, DrPH, HCLD/TS(ABB)
 5540 Overland Ave., San Diego, CA 92123
 Ph: 858-325-6400
 Fax: 858-268-4102



LIVE WELL
 SAN DIEGO

Carbapenemase Gene Detection

TEST INFORMATION	INFORMATION DETAILS
Is this test currently being performed?	Yes
Pre-Approval	<p>Yes, must be approved by the San Diego County Epidemiology Healthcare-Associated Infections (HAI) program <i>prior</i> to submission.</p> <p>Please coordinate with phs.hai.hhsa@sdcounty.ca.gov to ensure proper submission.</p> <p>Carbapenem resistant <i>Escherichia coli</i>, <i>Klebsiella oxytoca</i>, <i>Klebsiella pneumoniae</i>, <i>Klebsiella aerogenes</i>, <i>Enterobacter</i> species and <i>Pseudomonas aeruginosa</i> that meet the criteria listed in the ‘Acceptable Specimen type(s) and Collection Method’ section can be routinely submitted.</p> <p>Testing is available for carbapenem-resistant <i>Enterobacteriales</i> (other than those listed above) and <i>Acinetobacter</i> spp., but pre-approval is also required prior to submission. Contact the SDC HAI program for pre-approval.</p>
Supplemental Information Requested	N/A
Submittal Form	Specimens must be accompanied with a hard copy of the completed SDPHL Test Requisition (PDF).
Methodology	<p>FDA approved Cepheid GeneXpert Carba-R PCR-based assay for the genotypic detection of carbapenemase genes KPC, NDM, VIM, IMP-1 group and OXA-48 (also covering OXA-181 and OXA-232).</p> <p>Expanded AST (ExAST): Test provided through Antibiotic Resistance Laboratory Network (ARLN).</p>

Reflex Testing	<p>Very rarely isolates can carry a carbapenemase gene and not express it. These isolates may test positive for a carbapenemase gene via a genotypic assay but not demonstrate carbapenem resistance in a phenotypic assay such as AST. Isolates with a positive genotypic result that do not</p>
	<p>demonstrate carbapenem resistance can be forwarded to an ARLN lab for further testing.</p> <p>Please contact the SDC HAI program prior to submission of these or other unusual isolates.</p>
Acceptable Specimen Type(s) and Collection Method	<p>Pure culture isolate.</p> <p>Isolates must meet one of the following criteria:</p> <ol style="list-style-type: none"> 1. <u>Carbapenem resistant</u> Enterobacterales (CRE) <p>Isolate must be resistant to at least one relevant carbapenem, i.e., imipenem, ertapenem, doripenem, or meropenem.</p> 2. <u>Carbapenem-resistant</u> <i>Pseudomonas aeruginosa</i>(CRPA) <p>Isolate must be resistant to imipenem, meropenem, or doripenem by standard AST methods (i.e., MIC of ≥ 8 $\mu\text{g/mL}$) and Nonsusceptible (i.e., intermediate or resistant MIC $\geq 16\mu\text{g/ml}$) to cefepime or ceftazidime.</p> 3. Please Note: <p>If the species is intrinsically resistant to a carbapenem antibiotic (for example <i>Proteus</i> and <i>Morganella morganii</i> to imipenem) it must also be resistant to another relevant carbapenem.</p>
Minimum Volume Requested	None
Transport Medium	Nonselective nutrient or similar agar in tubes with leak-proof screw cap closures.
Specimen Labeling	Each specimen must be labeled with at least two unique patient identifiers (e.g., patient full name and date of birth).
Storage & Preservation of Specimen / Shipping Conditions	Store at ambient temperature.
Shipping Instructions	<p>Ship at ambient temperature.</p> <p>Ship specimens following instructions for Biological Substance – Category B (UN 3373) shipment.</p>

Shipping Address	<p style="text-align: center;">San Diego Public Health Laboratory ATTN: Specimen Receiving 5540 Overland Ave. San Diego, CA 92123 Phone: (858) 325-6400</p>
Turnaround Time	3 business days
Limitations	<ol style="list-style-type: none"> 1. Detection of resistance mechanisms is restricted to the target capacity of the assay’s primers and probes. Non-detected targets do not exclude the presence of variants, or other rare carbapenemase genes or resistance mechanisms. 2. Results are for epidemiological and infection control purposes and are not to be used as the sole means for clinical diagnosis, patient management, or treatment monitoring.
Rejection Criteria	<ol style="list-style-type: none"> 1. Samples with insufficient or conflicting labelling 2. Mixed culture 3. Specimen/sample types not meeting acceptance criteria
Additional Information	Testing is performed daily on regular business days
Contact Information	<p>For questions about submissions or to request special consideration if any of the above criteria cannot be met, please contact the SDCPHL Bacteriology/Parasitology/Antimicrobial Resistance section:</p> <p>Main Laboratory: 858-325-6459 Supervisor: Paul Temprendola (Cell): 619-917-2144 phslaboratory.hhsa@sdcounty.ca.gov</p>



San Diego County Public Health Laboratory

Jeremy Corrigan, DrPH, HCLD/TS(ABB)
5540 Overland Ave., San Diego, CA 92123
Ph: 858-694-2580
Fax: 619-692-8558



LIVE WELL
SAN DIEGO

Chlamydia Trachomatis and Neisseria Gonorrhoeae NAAT

CPT Code(s): 87491, 87591

TEST INFORMATION	INFORMATION DETAILS
Is this test currently being performed?	Yes
Pre-Approval	No
Supplemental Information Requested	Not Required
Submittal Form	Specimens must be accompanied by a hard copy of the completed SDPHL Test Requisition Form (PDF).
Methodology	Transcription Mediated Amplification (TMA)
Reflex Testing	None
Acceptable Specimen Type(s) and Collection Method	<ul style="list-style-type: none">• Patient-collected vaginal swabs• clinician-collected endocervical swabs• Female and male pharyngeal and rectal swabs• Female and male urine specimens.
Minimum Volume Requested	2mL urine transferred to Aptima urine collection device. Swabs must be inside Aptima Multi-test collection tube.
Specimen Labeling	Each specimen must be labeled with at least two unique patient identifiers, e.g., patient full name and date of birth
Storage & Preservation of Specimen / Shipping Conditions	Store and transport between 2-8°C (transport with ice packs in cooler)
Shipping Instructions	None
Shipping Address	San Diego Public Health Laboratory ATTN: Specimen Receiving 5540 Overland Ave. San Diego, CA 92123 Phone: 858-325-6400

Turnaround Time	3 business days from date of receipt.
Limitations	Urine specimens must not be under or overfilled. Add specimen to urine tube up to fill line as indicated on tube. Only one swab per collection site in each Multi-test collection tube.
Additional Information	Contact laboratory for further information
Contact Information	phslaboratory.hhsa@sdcounty.ca.gov



San Diego County Public Health Laboratory

Jeremy Corrigan, DrPH, HCLD/TS(ABB)
 5540 Overland Ave., San Diego, CA 92123
 Ph: 858-325-6400
 Fax: 858-268-4102



LIVE WELL
 SAN DIEGO

E. coli Confirmation, Serotyping, and Shiga Toxin Detection

TEST INFORMATION	INFORMATION DETAILS
Is this test currently being performed?	Yes
Pre-Approval	None
Supplemental Information Requested	N/A
Submittal Form	Specimens must be accompanied with a completed SDPHL Test Requisition (PDF).
Methodology	Phenotypic Identification, Enzyme immunoassay, Serogrouping, Matrix-Assisted Laser Desorption/Ionization - Time of Flight Mass Spectrometry (MALDI-TOF MS).
Reflex Testing	Shiga toxin-producing <i>Escherichia coli</i> (STEC) isolates are forwarded to the CA State laboratory for serogrouping, serotyping, and/or whole genome sequencing (WGS). WGS is for public health surveillance and epidemiologic investigations only (clinical reports are not issued).
Acceptable Specimen Type(s) and Collection Method	Pure culture isolate
Minimum Volume Requested	None
Transport Medium	Nonselective nutrient or similar agar in tubes with leak-proof screw cap closures.
Specimen Labeling	Each specimen must be labeled with at least two unique patient identifiers (e.g., patient full name and date of birth)
Storage & Preservation of Specimen / Shipping Conditions	Store at ambient temperature

Shipping Instructions	<p>Ship at ambient temperature</p> <p>Ship <i>Escherichia coli</i> O157 and <i>Shigella dysenteriae</i> isolates following instructions for <i>Category A</i> infectious substance affecting humans (UN 2814).</p> <p>Ship other <i>Escherichia</i> and <i>Shigella</i> isolates following instructions for Biological Substance – Category B (UN 3373) shipment.</p>
Shipping Address	<p>San Diego Public Health Laboratory ATTN: Specimen Receiving 5540 Overland Ave. San Diego, CA 92123 Phone: (858) 325-6400</p>
Turnaround Time	<p>5 business days</p>
Limitations	<p>A negative Shiga toxin test result does not preclude the possibility of the presence of Shiga toxins in the specimen which may occur if the level of antigen is below the detection limit of the test.</p>
Rejection Criteria	<ol style="list-style-type: none"> 1. Samples with insufficient or conflicting labelling 2. Mixed culture
Additional Information	<p>Testing frequency is daily, Monday–Friday 8 AM to 5 PM PT</p>
Contact Information	<p>Bacteriology/Parasitology/Antimicrobial Resistance section: Main Laboratory: 858-325-6459 Supervisor: Paul Temprendola (Cell): 619-917-2144 phslaboratory.hhsa@sdcounty.ca.gov</p>



San Diego County Public Health Laboratory

Jeremy Corrigan, DrPH, HCLD/TS(ABB)
 5540 Overland Ave., San Diego, CA 92123
 Ph: 858-325-6400
 Fax: 858-268-4102



LIVE WELL
 SAN DIEGO

Enteric Pathogen Culture – Primary Specimen
CPT Code(s): 87045, 87147

TEST INFORMATION	INFORMATION DETAILS
Is this test currently being performed?	Yes
Pre-Approval	Specimens are accepted only in coordination with the San Diego County Epidemiology Unit.
Supplemental Information Requested	None
Submittal Form	<p>Specimens must be accompanied by a completed SDPHL Test Requisition. Specify the following:</p> <ol style="list-style-type: none"> 1. Time of specimen collection. 2. Specimen number in the series of collections (e.g., '1 of 2', '2 of 2', etc.). <p>Targeted organisms include <i>Salmonella</i>, <i>Shigella</i>, <i>Campylobacter</i>, <i>Shiga-toxin Producing Escherichia coli</i> (STEC), <i>Yersinia</i>, <i>Vibrio</i>, <i>Aeromonas</i>, and <i>Plesiomonas shigelloides</i>.</p>
Methodology	Enrichment, Isolation, Phenotypic Testing, Serogrouping, Enzyme Immunoassay, Matrix-Assisted Laser Desorption/Ionization - Time of Flight Mass Spectrometry (MALDI-TOF MS)
Reflex Testing	<p>If Shiga toxin is detected by EIA, then Culture, Phenotypic Identification, and Serogrouping are performed.</p> <p>Shiga toxin-producing <i>Escherichia coli</i> (STEC) isolates are forwarded to the CA State laboratory for serogrouping, serotyping, and/or whole genome sequencing (WGS). WGS is for public health surveillance and epidemiologic investigations only (clinical reports are not issued).</p> <p><i>Escherichia coli</i> O157 and <i>Salmonella</i> isolates are forwarded to the CA State Laboratory for molecular characterization using Whole Genome Sequencing (WGS) for public health surveillance and epidemiologic investigations only (clinical reports are not issued).</p>

Acceptable Specimen Type(s) and Collection Method	<ol style="list-style-type: none"> 1. Feces in Para-Pak® C & S. 2. Unpreserved, fresh urine or stool specimens submitted within 2 hours of collection. <p>Specimen must be ≤ 5 days old.</p>
	<p>Specimens from the same patient must be collected ≥ 24 hours apart</p> <p>Collect in clean, dry container and then transfer stool into a C&S transport medium. Fluid level should reach line on vial.</p> <p>Urine is an acceptable specimen type if testing for S. Typhi.</p>
Minimum Volume Requested	<p>1 gram or 1 mL</p> <p>Sufficient feces in the Para-Pak® C & S vial will bring the liquid level up to the “fill to here” line. For solid stool, this is approximately the size of a 40 mm diameter piece.</p>
Transport Medium	Para-Pak® C & S, a modification of Cary-Blair medium
Specimen Labeling	<ol style="list-style-type: none"> 1. Two identifiers, including patient full name, and at least one other identifier (specimen accession number, date of birth, medical record number). 2. Date and time of collection.
Storage & Preservation of Specimen / Shipping Conditions	Store specimen at ambient or refrigerated temperatures (2-25°C).
Shipping Instructions	Ship specimens following instructions for Biological Substance – Category B (UN 3373) shipment.
Shipping Address	<p>San Diego Public Health Laboratory ATTN: Specimen Receiving 5550 Overland Ave. San Diego, CA 92123 Phone: (858) 325-6400</p>
Turnaround Time	5 business days
Limitations	A negative Shiga toxin test result does not preclude the possibility of the presence of Shiga toxins in the specimen which may occur if the level of antigen is below the detection limit of the test.
Rejection Criteria	<ol style="list-style-type: none"> 1. Specimen with insufficient or conflicting labelling 2. Specimens > 4 days old. 3. Leaking specimen

Contact Information

Bacteriology/Parasitology/Antimicrobial Resistance section:
Main Laboratory: 858-325-6459
Supervisor: Paul Temprendola (Cell): 619-917-2144
phslaboratory.hhsa@sdcounty.ca.gov



San Diego County Public Health Laboratory

Jeremy Corrigan, DrPH, HCLD/TS(ABB)
 5540 Overland Ave., San Diego, CA 92123
 Ph: 858-325-6400
 Fax: 858-268-4102



**LIVE WELL
 SAN DIEGO**

Hepatitis A PCR

TEST INFORMATION	INFORMATION DETAILS
Is this test currently being performed?	Yes
Pre-Approval	Yes
Supplemental Information Requested	<ul style="list-style-type: none"> Travel history Illness onset date Symptoms
Submittal Form	Specimens must be accompanied with a hard copy of the completed SDPHL Test Requisition Form (PDF).
Methodology	Hepatitis A PCR
Reflex Testing	None
Acceptable Specimen Type(s) and Collection Method	Serum
Minimum Volume Requested	1mL
Specimen Labeling	Each specimen must be labeled with at least two unique patient identifiers, e.g., patient full name and date of birth.
Storage & Preservation of Specimen / Shipping Conditions	Transport specimen between 4-25°C. Use ice packs when transporting specimen. For long-term storage, freeze specimen.
Shipping Instructions	Ship specimens and a hard copy of the completed submittal forms.

Shipping Address	San Diego Public Health Laboratory ATTN: Specimen Receiving 5540 Overland Ave. San Diego, CA 92123 Phone: 858-325-6400
Turnaround Time	7 business days
Limitations	Specimens tested once a week
Additional Information	Call laboratory for any questions regarding specimen collection.
Contact Information	phslaboratory.hhsa@sdcounty.ca.gov



San Diego County Public Health Laboratory

Jeremy Corrigan, DrPH, HCLD/TS(ABB)
 5540 Overland Ave., San Diego, CA 92123
 Ph: 858-325-6400
 Fax: 858-268-4102



LIVE WELL
 SAN DIEGO

Hepatitis B Reflex Panel
CPT Code(s): 86704, 87340, 87341, 86706

TEST INFORMATION	INFORMATION DETAILS
Is this test currently being performed?	No
Pre-Approval	No
Supplemental Information Requested	None
Submittal Form	Specimens must be accompanied with a hard copy of the completed SDPHL Test Requisition (PDF).
Methodology	Chemiluminescent Microparticle Immunoassay (CMIA)
Reflex Testing	Anti-Hepatitis B Surface Ag Quantitative / Hepatitis B surface antigen (qualitative)
Acceptable Specimen Type(s) and Collection Method	Serum collected from Serum separator tubes or red top tubes with no anticoagulants
Minimum Volume Requested	1mL
Specimen Labeling	Each specimen must be labeled with at least two unique patient identifiers, e.g., patient full name and date of birth.
Storage & Preservation of Specimen / Shipping Conditions	Specimens collected should be frozen and sent on ice packs to the laboratory.
Shipping Instructions	Ship specimens and a hard copy of the completed submittal forms.

Shipping Address	San Diego Public Health Laboratory ATTN: Specimen Receiving 5540 Overland Ave. San Diego, CA 92123 Phone: 858-325-6400
Turnaround Time	7 business days
Limitations	Specimens may be rejected for the following: heat inactivation, pooled samples, microbial contamination, and/or grossly hemolyzed.
Additional Information	Call the laboratory for any questions on specimen collection or transport
Contact Information	phslaboratory.hhsa@sdcounty.ca.gov



San Diego County Public Health Laboratory

Jeremy Corrigan, DrPH, HCLD/TS(ABB)
5540 Overland Ave., San Diego, CA 92123
Ph: 858-694-2580
Fax: 619-692-8558



**LIVE WELL
SAN DIEGO**

**Hepatitis C Antibody Reflex Panel
CPT: 86803, 87522**

TEST INFORMATION	INFORMATION DETAILS
Is this test currently being performed?	Yes
Pre-Approval	No
Supplemental Information Requested	Not Required
Submittal Form	Specimens must be accompanied with a hard copy of the completed SDPHL Test Requisition Form (PDF)
Methodology	Chemiluminescent Microparticle Immunoassay (CMIA)
Reflex Testing	Hepatitis C Viral Load (Transcription Mediated Amplification)
Acceptable Specimen Type(s) and Collection Method	Serum
Minimum Volume Requested	2mL
Specimen Labeling	Each specimen must be labeled with at least two unique patient identifiers, e.g., patient full name and date of birth.
Storage & Preservation of Specimen / Shipping Conditions	From date of collection: room temperature up to 3 days; 2 to 8°C up to 7 days; -20°C or colder greater than 7 days
Shipping Instructions	Ship specimens and a hard copy of the completed submittal forms.
Shipping Address	San Diego Public Health Laboratory ATTN: Specimen Receiving 5540 Overland Ave. San Diego, CA 92123 Phone: 858-325-6400
Turnaround Time	7 business days

Limitations	Specimens that are hemolyzed, pooled, heat inactivated, or grossly contaminated will not be tested.
Additional Information	Call the laboratory for any questions on specimen collection or transport.
Contact Information	phslaboratory.hhsa@sdcounty.ca.gov



San Diego County Public Health Laboratory

Jeremy Corrigan, DrPH, HCLD/TS(ABB)
5540 Overland Ave., San Diego, CA 92123
Ph: 858-694-2580
Fax: 619-692-8558



**LIVE WELL
SAN DIEGO**

**Herpes Simplex Virus 1&2 (HSV 1/2) NAAT
CPT Code(s): 87529**

TEST INFORMATION	INFORMATION DETAILS
Is this test currently being performed?	Yes
Pre-Approval	No
Supplemental Information Requested	No
Submittal Form	Specimens must be accompanied by a hard copy of the completed SDPHL Test Requisition Form (PDF).
Methodology	Transcription Mediated Amplification (TMA)
Reflex Testing	None
Acceptable Specimen Type(s) and Collection Method	<p>Swab specimens from anogenital and oral lesions in Aptima Multi-test Swab Specimen collection tube containing STM (Specimen Transport Medium).</p> <p>NOTE: The Aptima HSV 1 and 2 assay is not FDA cleared for swab specimens from oral lesions. This assay was validated and its performance characteristics determined by San Diego County Public Health Laboratory.</p>
Minimum Volume Requested	Use Aptima Multi-test Collection tube and swab
Specimen Labeling	Each specimen must be labeled with at least two unique patient identifiers, e.g., patient full name and date of birth.
Storage & Preservation of Specimen / Shipping Conditions	Specimens collected in the Aptima Multi-test Swab Collection Kit (STM) should be stored and transported at 2°C to 30°C
Shipping Instructions	Ship specimens and a hard copy of the completed submittal forms.
Shipping Address	<p>San Diego Public Health Laboratory ATTN: Specimen Receiving 5540 Overland Ave. San Diego, CA 92123 Phone: 858-325-6400</p>

Turnaround Time	7 business days from date of receipt
Limitations	Collection tubes containing different swabs or lacking swabs will not be tested
Additional Information	For more information on specimen collection, please call the laboratory.
Contact Information	phslaboratory.hhsa@sdcounty.ca.gov



San Diego County Public Health Laboratory

Jeremy Corrigan, DrPH, HCLD/TS(ABB)
5540 Overland Ave., San Diego, CA 92123
Ph: 858-694-2580
Fax: 619-692-8558



LIVE WELL
SAN DIEGO

HIV-1/HIV-2 Confirmatory Test
CPT Code: 86701

TEST INFORMATION	INFORMATION DETAILS
Is this test currently being performed?	Yes
Pre-Approval	No
Supplemental Information Requested	No
Submittal Form	Specimens must be accompanied with a hard copy of the completed SDPHL Test Requisition (PDF).
Methodology	Immunochromatographic Assay
Reflex Testing	None
Acceptable Specimen Type(s) and Collection Method	Serum collected in serum separator tubes or red top tubes
Minimum Volume Requested	1mL
Specimen Labeling	Each specimen must be labeled with at least two unique patient identifiers, e.g., patient full name and date of birth
Storage & Preservation of Specimen / Shipping Conditions	Specimens may be stored and transported at room temperature for 3 days after collection. Store specimens at 2-8°C between 3-7 days from collection. If specimen cannot be tested within 7 days from collection, remove serum from clot or separator gel and freeze at -20°C
Shipping Instructions	Ship specimens and a hard copy of the completed submittal forms.
Shipping Address	San Diego Public Health Laboratory ATTN: Specimen Receiving 5540 Overland Ave. San Diego, CA 92123 Phone: 858-325-6400

Turnaround Time	3 business days
Limitations	Specimens with the following will not be tested: heat inactivation, pooled samples, microbial contamination, and/or grossly hemolyzed.
Additional Information	For more information on specimen collection, please call the laboratory.
Contact Information	phslaboratory.hhsa@sdcounty.ca.gov



San Diego County Public Health Laboratory

Jeremy Corrigan, DrPH, HCLD/TS(ABB)
5540 Overland Ave., San Diego, CA 92123
Ph: 858-694-2580
Fax: 619-692-8558



LIVE WELL
SAN DIEGO

HIV-1/2 Ag/Ab Reflex Panel

CPT: 87389, 86701

TEST INFORMATION	INFORMATION DETAILS
Is this test currently being performed?	Yes
Pre-Approval	No
Supplemental Information Requested	No
Submittal Form	Specimens must be accompanied with a hard copy of the completed SDPHL Test Requisition (PDF).
Methodology	Chemiluminescence Immunoassay for qualitative detection of human immunodeficiency virus (HIV) p24 antigen and antibodies to HIV type 1 and/or type 2 (HIV-2)
Reflex Testing	Immunochromatographic Assay (differential HIV-1/HIV-2 assay)
Acceptable Specimen Type(s) and Collection Method	Serum collected in serum separator tubes or red top tubes
Minimum Volume Requested	1mL
Specimen Labeling	Each specimen must be labeled with at least two unique patient identifiers, e.g., patient full name and date of birth
Storage & Preservation of Specimen / Shipping Conditions	Specimens may be stored and transported at room temperature for 3 days after collection. Store specimens at 2-8°C between 3-7 days from collection. If specimen cannot be tested within 7 days from collection, remove serum from clot or separator gel and freeze at -20°C
Shipping Instructions	Ship specimens and a hard copy of the completed submittal forms.
Shipping Address	San Diego Public Health Laboratory ATTN: Specimen Receiving 5540 Overland Ave. San Diego, CA 92123 Phone: 858-325-6400

Turnaround Time	5 business Days
Limitations	Specimens with the following will not be tested: heat inactivation, pooled samples, microbial contamination, and/or grossly hemolyzed.
Additional Information	For more information on specimen collection, please call the laboratory.
Contact Information	phslaboratory.hhsa@sdcounty.ca.gov



San Diego County Public Health Laboratory

Jeremy Corrigan, DrPH, HCLD/TS(ABB)
5540 Overland Ave., San Diego, CA 92123
Ph: 858-694-2580
Fax: 619-692-8558



LIVE WELL
SAN DIEGO

HIV-1 Viral Load
CPT Code(s): 87536

TEST INFORMATION	INFORMATION DETAILS
Is this test currently being performed?	Yes
Pre-Approval	No
Supplemental Information Requested	Yes: Previous positive results for HIV-1
Submittal Form	Specimens must be accompanied by a hard copy of the completed SDPHL Test Requisition Form (PDF).
Methodology	Real-time Reverse Transcription Polymerase Chain Reaction (RT-PCR)
Reflex Testing	None
Acceptable Specimen Type(s) and Collection Method	The following blood tube types are acceptable for testing: <ul style="list-style-type: none">• Acid Citrate Dextrose (ACD),• K2-EDTA, K3-EDTA• Plasma Preparation Tube (PPT).
Minimum Volume Requested	A minimum volume of 1.0 mL in primary blood collection tubes.
Specimen Labeling	Each specimen must be labeled with at least two unique patient identifiers, e.g., patient full name and date of birth.
Storage & Preservation of Specimen / Shipping Conditions	Whole blood: Store at 15–30°C for 12–24 hours prior to plasma separation. Whole blood can be held at 2–8°C for 2 days. Plasma: Store at 2–8°C for up to 3 days or frozen at –20°C to –70°C for longer storage and avoid more than two freeze-thaws. Ship specimens under temperature-controlled conditions that match their storage requirements
Shipping Instructions	None
Shipping Address	San Diego Public Health Laboratory ATTN: Specimen Receiving 5540 Overland Ave. San Diego, CA 92123 Phone: 858-325-6400

Turnaround Time	14 business days from date of receipt
Limitations	Specimen storage and handling outside of collection guidelines may result in erroneous results
Additional Information	For more information on specimen collection, please call the laboratory.
Contact Information	phslaboratory.hhsa@sdcounty.ca.gov



San Diego County Public Health Laboratory

Jeremy Corrigan, DrPH, HCLD/TS(ABB)
 5540 Overland Ave., San Diego, CA 92123
 Ph: 858-325-6400
 Fax: 858-268-4102



LIVE WELL
 SAN DIEGO

Influenza PCR and Subtyping

TEST INFORMATION	INFORMATION DETAILS
Is this test currently being performed?	Yes
Pre-Approval	No
Supplemental Information Requested	For subtyping, prior test results for Influenza type need to be detailed in test requisition form.
Submittal Form	Specimens must be accompanied with a hard copy of the completed SDPHL Test Requisition Form (PDF).
Methodology	Influenza PCR and Subtyping
Reflex Testing	Influenza A/B subtyping
Acceptable Specimen Type(s) and Collection Method	<p>Upper respiratory tract specimens: Nasopharyngeal swabs, nasal swabs, throat swabs, nasal aspirate, nasal wash, dual nasopharyngeal swab/throat swab).</p> <p>Lower respiratory tract specimens: Bronchoalveolar lavage, bronchial wash, tracheal aspirate, sputum, lung tissue).</p>
Minimum Volume Requested	1mL
Transport Medium	Viral Transport Media (VTM)
Specimen Labeling	Each specimen must be labeled with at least two unique patient identifiers, e.g., patient full name and date of birth.
Storage & Preservation of Specimen / Shipping Conditions	Specimens must be transported in VTM at 2-8°C and stored refrigerated for up to 72 hours before processing. If unable to transport or process within 72 hours after collection, freeze at ≤ -70 °C and transport frozen until processing.

Shipping Instructions	Ship specimens and a hard copy of the completed submittal forms.
Shipping Address	San Diego Public Health Laboratory ATTN: Specimen Receiving 5540 Overland Ave. San Diego, CA 92123 Phone: 858-325-6400
Turnaround Time	In season: 4 business days from receipt. Out of season: 7 business days from receipt.
Limitations	Swab specimens must be collected using only synthetic tip swabs such as nylon or Dacron®), and an aluminum or plastic shaft. Calcium alginate swabs are unacceptable and cotton swabs with wooden shafts are not recommended.
Additional Information	Call laboratory for any questions regarding specimen collection.
Contact Information	phslaboratory.hhsa@sdcounty.ca.gov



San Diego County Public Health Laboratory

Jeremy Corrigan, DrPH, HCLD/TS(ABB)

5540 Overland Ave., San Diego, CA 92123

Ph: 858-694-2580

Fax: 619-692-8558



LIVE WELL
SAN DIEGO

Measles PCR CPT: 87798

TEST INFORMATION	INFORMATION DETAILS
Is this test currently being performed?	Yes
Pre-Approval	Pre-approval is required for testing
Supplemental Information Requested	<ul style="list-style-type: none">• Symptoms• Onset date• Travel history• Vaccine status
Submittal Form	Specimens must be accompanied with a hard copy of the completed SDPHL Test Requisition Form (PDF).
Methodology	Real Time RT-PCR
Reflex Testing	None
Acceptable Specimen Type(s) and Collection Method	Nasopharyngeal swab in Viral Transport Media (VTM). Urine submitted to laboratory within 24 hours from collection.
Minimum Volume Requested	2-3 mLs of VTM (Nasopharyngeal swab). 50-100 mL volume for urine (no minimum)
Specimen Labeling	Each specimen must be labeled with at least two unique patient identifiers, e.g., patient full name and date of birth.
Storage & Preservation of Specimen / Shipping Conditions	Ship unprocessed urine on ice packs to the laboratory within 24 hours of collection. DO NOT FREEZE unprocessed urine. Swabs in VTM can be refrigerated (2-8°C) for 72 hours. After 72 hours, VTM tubes must be frozen. Transport frozen VTMs on dry ice or ice packs
Shipping Instructions	Ship specimens and a hard copy of the completed submittal forms.

Shipping Address	San Diego Public Health Laboratory ATTN: Specimen Receiving 5540 Overland Ave. San Diego, CA 92123 Phone: 858-325-6400
Turnaround Time	Up to 48 hours from specimen receipt.
Limitations	Urine for testing will only be processed at laboratory within 24 hours from collection. Frozen urine or urine processed at submitting facility will not be tested.
Additional Information	For more information on specimen collection, please call the laboratory.
Contact Information	phslaboratory.hhsa@sdcounty.ca.gov



San Diego County Public Health Laboratory

Jeremy Corrigan, DrPH, HCLD/TS(ABB)
5540 Overland Ave., San Diego, CA 92123
Ph: 858-694-2580
Fax: 619-692-8558



LIVE WELL
SAN DIEGO

MPOX PCR
CPT: 87593

TEST INFORMATION	INFORMATION DETAILS
Is this test currently being performed?	Yes
Pre-Approval	Prior approval is required
Supplemental Information Requested	
Submittal Form	Specimens must be accompanied with a hard copy of the completed SDPHL Test Requisition Form (PDF).
Methodology	Real Time PCR
Reflex Testing	None
Acceptable Specimen Type(s) and Collection Method	Lesion swab specimens placed in Viral Transport Media (VTM)
Minimum Volume Requested	Swab in 3mL VTM
Specimen Labeling	Each specimen must be labeled with at least two unique patient identifiers, e.g., patient full name and date of birth.
Storage & Preservation of Specimen / Shipping Conditions	Swabs in VTM can be refrigerated (2-8°C) for 7 days from date of collection. After 7 days, VTM tubes must be frozen and can be tested up to 30 days from collection. Transport frozen VTMs on dry ice or ice packs.
Shipping Instructions	Ship specimens and a hard copy of the completed submittal forms.
Shipping Address	San Diego Public Health Laboratory ATTN: Specimen Receiving 5540 Overland Ave. San Diego, CA 92123 Phone: 858-325-6400

Turnaround Time	5 business days
Limitations	Use of other collection media and/or specimen types may lead to false positive, false negative or invalid results. Do not use calcium alginate swabs or swabs with wooden shafts, as they may contain substances that inactivate some viruses and may inhibit molecular test.
Additional Information	For more information on specimen collection, please call the laboratory.
Contact Information	phslaboratory.hhsa@sdcounty.ca.gov



San Diego County Public Health Laboratory

Jeremy Corrigan, DrPH, HCLD/TS(ABB)
 5540 Overland Ave., San Diego, CA 92123
 Ph: 858-694-2580
 Fax: 619-692-8558



**LIVE WELL
 SAN DIEGO**

**Mumps PCR
 CPT: 87798**

TEST INFORMATION	INFORMATION DETAILS
Is this test currently being performed?	No
Pre-Approval	Prior approval is needed for testing.
Supplemental Information Requested	<ul style="list-style-type: none"> Symptoms Onset date Travel history Vaccine status
Submittal Form	Specimens must be accompanied with a hard copy of the completed SDPHL Test Requisition Form (PDF).
Methodology	Real time RT- PCR
Reflex Testing	None
Acceptable Specimen Type(s) and Collection Method	<ol style="list-style-type: none"> 1. Buccal (inside of the cheek) swabs 2. Nasopharyngeal swabs 3. Oropharyngeal (throat) swabs <p>Following collection, place swabs in Viral Transport Media (VTM)</p>
Minimum Volume Requested	1mL
Specimen Labeling	Each specimen must be labeled with at least two unique patient identifiers, e.g., patient full name and date of birth.
Storage & Preservation of Specimen / Shipping Conditions	Transport in VTM at 2-8°C and store/transport refrigerated (2-8°C) for up to 72 hours before processing. If unable to transport or process within 72 hours after collecting, freeze at ≤ -70 °C until processed.
Shipping Instructions	Ship specimens and a hard copy of the completed submittal forms.

Shipping Address	San Diego Public Health Laboratory ATTN: Specimen Receiving 5540 Overland Ave. San Diego, CA 92123 Phone: 858-325-6400
Turnaround Time	72 hours from date of receipt
Limitations	Do not use calcium alginate swabs or swabs with wooden shafts, as they may contain substances that inactivate some viruses and may inhibit molecular test.
Additional Information	For more information on specimen collection, please call the laboratory.
Contact Information	phslaboratory.hhsa@sdcounty.ca.gov



San Diego County Public Health Laboratory

Jeremy Corrigan, DrPH, HCLD/TS(ABB)
 5540 Overland Ave., San Diego, CA 92123
 Ph: 858-325-6400

Fax: 858-268-4102



LIVE WELL
 SAN DIEGO

Mycobacterium – Primary Drug Susceptibility Testing (DST) Panel	
TEST INFORMATION	INFORMATION DETAILS
Is this test currently being performed?	Yes
Pre-Approval	No
Supplemental Information Requested	Date of onset/exposure, travel history, previous lab results, symptoms, therapy, treatment outcome, other relevant information
Submittal Form	Specimens must be accompanied with a hard copy of the completed SDPHL Test Requisition (PDF).
Methodology	First-line drug susceptibility testing is performed on <i>Mycobacteria tuberculosis</i> complex (MTBC) using the BacTec mycobacterium growth indicator tube (MGIT) broth-based method with primary drugs: isoniazid (INH), rifampin (RIF), ethambutol (EMB), and pyrazinamide (PZA). Testing is permitted on a patient once every 3 months.
Reflex Testing	No
Acceptable Specimen Type(s) and Collection Method	Pure mycobacterial isolate <14 days old preferred (up to 2 months old) on Lowenstein Jensen (LJ) or Middlebrook slant. Minimum of 1+ growth on slant required.
Minimum Volume Requested	1+ growth, pure isolate
Transport Medium (if using)	L J or Middlebrook slant
Specimen Labeling	Each specimen must be labeled with at least two unique patient identifiers, e.g., patient full name and date of birth.
Storage & Preservation of Specimen / Shipping Conditions	Transport at room temperature. Category A shipment.
Shipping Instructions	Ship specimens and a hard copy of the completed submittal forms.

Shipping Address	<p style="text-align: center;">San Diego Public Health Laboratory ATTN: Specimen Receiving 5540 Overland Ave. San Diego, CA 92123 Phone: 858-325-6400</p>
Turnaround Time	DSTs – Performed twice a week, TAT= 4-6 weeks
Limitations	<p>Testing is permitted on a patient once every 3 months.</p> <ul style="list-style-type: none"> • The following conditions will result in a specimen being rejected as unsatisfactory: • Isolate is not pure growth. • Isolate culture is more than 2 months old. • Specimen leaked in transit. • Specimen has no name on the label. • Specimen is labeled with information that does not match the requisition form. • Outer surfaces of collection container are visibly contaminated. • Requisition form is visibly contaminated.
Additional Information	<ul style="list-style-type: none"> • Specimens resistant to Isoniazid and Rifampin are sent to the California Department of Public Health (CDPH) at the request of the submitter. • Specimens requiring second line antimicrobial testing are forwarded to the CDPH at the request of the submitter. • Specimens requiring linezolid and cycloserine susceptibilities are sent to National Jewish at the request of the submitter. • Specimens that require MDDR testing are sent to the CDC at the request of the submitter after approval is received from the CDC.
Contact Information	phslaboratory.hhsa@sdcounty.ca.gov



San Diego County Public Health Laboratory

Jeremy Corrigan, DrPH, HCLD/TS(ABB)
 5540 Overland Ave., San Diego, CA 92123
 Ph: 858-325-6400
 Fax: 858-268-4102



LIVE WELL
 SAN DIEGO

**Mycobacterium tuberculosis Complex (MTBC)
 /Rifampin (RIF) Susceptibility PCR Assay
 CPT Code(s): 87556, 87798**

TEST INFORMATION	INFORMATION DETAILS
Is this test currently being performed?	Yes
Pre-Approval	No
Supplemental Information Requested	Date of onset/exposure, travel history, previous lab results, symptoms, therapy, treatment outcome, other relevant information
Submittal Form	Specimens must be accompanied with a hard copy of the completed SDPHL Test Requisition (PDF).
Methodology	Cepheid MTB/RIF GeneXpert assay: A multiplexed nucleic acid amplification test (NAAT) that detects the presence of MTBC DNA and mutations of the rpoB gene that is associated with rifampin resistance.
Reflex Testing	No
Acceptable Specimen Type(s) and Collection Method	<ul style="list-style-type: none"> • A minimum 1.0 mL sediment sample from acid fast bacillus (AFB) smear-positive respiratory specimen that has been processed using the NaLC-NaOH method of Kent and Kubica. • Smear negative respiratory samples may be tested; however, this method is less sensitive than other available methods.
Minimum Volume Requested	Minimum 1.0 mL for processed sediment sample
Transport Medium (if using)	N/A
Specimen Labeling	Each specimen must be labeled with at least two unique patient identifiers, e.g., patient full name and date of birth.
Storage & Preservation of Specimen / Shipping Conditions	Processed sediments ≤5 days old transported at 2-8°C. Isolates and broth cultures of <14 days growth can be transported at 25°C.
Shipping Instructions	Ship specimens and a hard copy of the completed submittal forms.

Shipping Address	<p style="text-align: center;">San Diego Public Health Laboratory ATTN: Specimen Receiving 5540 Overland Ave. San Diego, CA 92123 Phone: 858-325-6400</p>
Turnaround Time	<ul style="list-style-type: none"> • MTB/RIF Assay – Performed as needed, TAT=1 business days
Limitations	<p>The following conditions will result in a specimen being rejected as unsatisfactory:</p> <ul style="list-style-type: none"> • Processed sputum specimens older than 5 days. • Isolates and broth cultures older than 14 days. • Specimen leaked in transit. • Specimen has no name on the label. • Specimen is labeled with information that does not match the requisition form. • Outer surfaces of collection container are visibly contaminated. • Requisition form is visibly contaminated.
Additional Information	<p>If RIF resistance is detected, the isolate is sent to the California Department of Public Health (CDPH) for sequencing-based DST confirmation.</p>
SDPHL Points of Contact	<p style="text-align: center;">phslaboratory.hhsa@sdcounty.ca.gov</p>



San Diego County Public Health Laboratory

Jeremy Corrigan, DrPH, HCLD/TS(ABB)
 5540 Overland Ave., San Diego, CA 92123
 Ph: 858-325-6400
 Fax: 858-268-4102



LIVE WELL
 SAN DIEGO

***Neisseria gonorrhoeae* Antibiotic Susceptibility Testing (AST) for Azithromycin, Ceftriaxone, and Cefixime**

TEST INFORMATION	INFORMATION DETAILS
Is this test currently being performed?	Yes
Pre-Approval	<p>Yes, testing must be approved by the San Diego County STD Branch of Public Health Services or a regional Public Health Department</p> <p>No, if isolate has resistance or decreased susceptibility to ceftriaxone or cefixime</p>
Supplemental Information Requested	None
Submittal Form	<p>Specimens must be accompanied by a completed SDPHL Test Requisition Form</p> <p>SD County Test Requisition Updated 07.23.2024.pdf sandiegocounty.gov</p>
Methodology	<p>bioMérieux GC Etest uses gradient strip technology to determine the minimum inhibitory concentration (MIC) of antimicrobial agents against <i>N. gonorrhoeae</i>.</p>
Reflex Testing	<p><i>N. gonorrhoeae</i> isolates with decreased susceptibility to cefixime (MIC ≥ 0.25 $\mu\text{g/mL}$), ceftriaxone (MIC ≥ 0.125 $\mu\text{g/mL}$), or azithromycin (MIC > 16.0 $\mu\text{g/mL}$) will be forwarded to the CA State Laboratory for further testing.</p>
Acceptable Specimen Type(s) and Collection Method	<p>Pure, fresh, live culture of <i>N. gonorrhoeae</i> submitted on chocolate agar, modified Thayer Martin agar, or in TSB broth with 15% glycerol.</p>
Minimum Volume Requested	N/A

<p>Transport Medium</p>	<p>Prepare culture for transportation:</p> <ol style="list-style-type: none"> 1. Obtain fresh culture: Grow a pure <i>N. gonorrhoeae</i> isolate at 35°C in 5% CO₂ on suitable media for <i>N. gonorrhoeae</i> (chocolate agar or modified Thayer-Martin) for 24-48 hours, until visible growth is achieved. Prepare and submit the culture fresh (24-48 hr.) at the time of shipping. 2. Shipping Options: Frozen Cryotube with TSB and 15% Glycerol: Heavily inoculate a cryotube with fresh growth.
	<p>Immediately place it in a -60°C or lower freezer. Once fully frozen, ship the isolate on dry ice.</p> <p>Agar Slant: Heavily inoculate a chocolate (or other suitable media for GC) slant with fresh growth. Incubate at 35°C with 5% CO₂ until visible growth appears (18-24 hours is ideal). Close the cap tightly and ship at ambient temperature.</p> <p>Agar Plate: Heavily inoculate a chocolate (or other suitable media for GC) plate with fresh growth. Incubate at 35°C with 5% CO₂ until visible growth appears (18-24 hours is ideal). Seal the plate lid tightly with parafilm, place it in a zip-lock biohazard bag, and ship at ambient temperature.</p>
<p>Specimen Labeling</p>	<p>Each specimen must be labeled with at least two identifiers, including patient full name, and at least one other identifier (specimen accession number, date of birth, medical record number)</p>
<p>Storage & Preservation of Specimen / Shipping Conditions</p>	<p>Culture isolates may be shipped at ambient temperature or frozen in TSB with 15% glycerol on dry ice.</p>
<p>Shipping Instructions</p>	<p>Ship isolates grown on media that supports <i>N. gonorrhoeae</i> at ambient temperature or ship cultures frozen in TSB with 15% glycerol on dry ice.</p> <p>Ship specimens and a hard copy of the completed submittal forms.</p> <p>Ship specimens following instructions for Biological Substance – Category B (UN 3373) shipment.</p>
<p>Shipping Address</p>	<p>San Diego Public Health Laboratory ATTN: Specimen Receiving 5540 Overland Ave. San Diego, CA 92123 Phone: (858) 325-6400</p>

Turnaround Time	10 calendar days
Limitations	Pure culture isolates must be viable for testing.
Rejection Criteria	<ul style="list-style-type: none"> • Isolate submissions with insufficient or conflicting labelling • Broken or leaking samples • Isolates that are too old or non-viable • Mixed cultures <p>Primary patient samples submitted from entities other than the San Diego County HIV, STD and Hepatitis Branch of Public Health Services or a regional public health department.</p>
Additional Information	None
Contact Information	<p>Bacteriology/Parasitology/Antimicrobial Resistance section: Main Laboratory: 858-325-6459 Supervisor: Paul Temprendola (Cell): 619-917-2144 phslaboratory.hhsa@sdcounty.ca.gov</p>



San Diego County Public Health Laboratory

Jeremy Corrigan, DrPH, HCLD/TS(ABB)
 5540 Overland Ave., San Diego, CA 92123
 Ph: 858-325-6400
 Fax: 858-268-4102



LIVE WELL
 SAN DIEGO

***Neisseria gonorrhoeae* Culture – Primary Specimen**

TEST INFORMATION	INFORMATION DETAILS
Is this test currently being performed?	Yes
Pre-Approval	Specimens are accepted only in coordination with the San Diego County HIV, STD and Hepatitis Branch of Public Health.
Supplemental Information Requested	None
Submittal Form	Specimens must be accompanied with a hard copy of the completed SDPHL Test Requisition.
Methodology	Isolation, Phenotypic Testing, Matrix-Assisted Laser Desorption/Ionization - Time of Flight Mass Spectrometry (MALDI-TOF MS)
Reflex Testing	Culture-positive specimens will be reflexed to <i>Neisseria gonorrhoeae</i> antibiotic susceptibility testing by the Etest method.

<p>Acceptable Specimen Type(s) and Collection Method</p>	<p>Modified Thayer Martin (MTM) culture plate inoculated with a swab from the urethra, pharynx, rectum, vagina, or endocervix.</p> <ol style="list-style-type: none"> 1. Roll swab across the agar surface in a Z pattern. 2. If Gram stain is to be prepared: <ol style="list-style-type: none"> a. Roll swab over the clean glass slide labeled with patient identifier. Do not rub vigorously since cellular distortion may occur. Prevent over-inoculating the slide with pus to prevent overflow of specimen off the slide during transport. b. Insert the slide into the plastic slide mailer c. Secure the snap-top lid. 3. Place culture in a candle can as soon as possible (within 15 minutes). Be sure to relight the candle each time the can is opened. <ol style="list-style-type: none"> a. Open the candle jar. b. Wet a few paper towels, express the excess water, and place them flat in the bottom of the candle jar. c. Place culture plate(s) on top of the damp towel and secure the lids with a rubber band, if necessary
	<ol style="list-style-type: none"> d. Place petri dish on top of inoculated plates and place the candle in the petri dish. Light the candle. Seal the jar completely by replacing the lid. Do not disturb the jar until the candle is extinguished. When extinguished, the concentration of CO₂ in the jar is adequate. <p>Attach the requisition slips to the outside of the jar with a rubber band or tape.</p>
<p>Minimum Volume Requested</p>	<p>N/A</p>
<p>Transport Medium</p>	<p>Modified Thayer Martin (MTM) culture plate</p>
<p>Specimen Labeling</p>	<p>Label each plate with a demographic label and a barcode label. Each plate must be labeled with at least two unique patient identifiers (e.g., patient full name and date of birth) and the anatomical site.</p>
<p>Storage & Preservation of Specimen / Shipping Conditions</p>	<p>Candle jar in a 35-37°C incubator</p>
<p>Shipping Instructions</p>	<p>Ship in a candle jar at ambient temperature.</p>

Shipping Address	San Diego Public Health Laboratory ATTN: Specimen Receiving 5540 Overland Ave. San Diego, CA 92123 Phone: (858) 325-6400
Turnaround Time	5 days
Limitations	None
Rejection Criteria	Samples with insufficient or conflicting labelling
Additional Information	N/A
Contact Information	Bacteriology/Parasitology/Antimicrobial Resistance section: Main Laboratory: 858-325-6459 Supervisor: Paul Temprendola (Cell): 619-917-2144 phslaboratory.hhsa@sdcounty.ca.gov



San Diego County Public Health Laboratory

Jeremy Corrigan, DrPH, HCLD/TS(ABB)
5540 Overland Ave., San Diego, CA 92123
Ph: 858-694-2580
Fax: 619-692-8558



LIVE WELL
SAN DIEGO

Norovirus PCR CPT: 87798

TEST INFORMATION	INFORMATION DETAILS
Is this test currently being performed?	Yes
Pre-Approval	Prior approval is required for testing
Supplemental Information Requested	<ul style="list-style-type: none">• Symptoms• Illness onset date• Travel history
Submittal Form	Specimens must be accompanied with a hard copy of the completed SDPHL Test Requisition Form (PDF).
Methodology	RT-PCR
Reflex Testing	None
Acceptable Specimen Type(s) and Collection Method	Stool specimens collected in sterile containers without preservatives. Ideal specimens are those collected within 48-72 hours after onset of symptoms while the stools are still liquid or semi-solid.
Minimum Volume Requested	25 grams of stool
Transport Medium	None
Specimen Labeling	Each specimen must be labeled with at least two unique patient identifiers, e.g., patient full name and date of birth.
Storage & Preservation of Specimen / Shipping Conditions	Stool specimens are stable at 2-8°C for up to 5 days after collection. If unable to test within 5 days, specimens may be frozen at -20°C or -70°C.
Shipping Instructions	Ship specimens and a hard copy of the completed submittal forms.
Shipping Address	San Diego Public Health Laboratory ATTN: Specimen Receiving 5540 Overland Ave. San Diego, CA 92123 Phone: 858-325-6400

Turnaround Time	3 business days from receipt date at the laboratory
Limitations	Stool specimens in transport media will not be tested. Specimens are batch tested weekly.
Additional Information	For more information on specimen collection, please call the laboratory.
Contact Information	phslaboratory.hhsa@sdcounty.ca.gov



San Diego County Public Health Laboratory

Jeremy Corrigan, DrPH, HCLD/TS(ABB)
 5540 Overland Ave., San Diego, CA 92123
 Ph: 858-325-6400
 Fax: 858-268-4102



LIVE WELL
 SAN DIEGO

Plasmodium species, Babesia, and Other Blood Parasites

TEST INFORMATION	INFORMATION DETAILS
Is this test currently being performed?	Yes
Pre-Approval	No
Supplemental Information Requested	<ol style="list-style-type: none"> 1. Travel History (name of country and when visited) 2. Previous Malaria Diagnosis and Species Identified 3. Blood Transfusion or Needle Use
Submittal Form	Specimens must be accompanied with a hard copy of the completed SDPHL Test Requisition.
Methodology	Microscopic Examination
Reflex Testing	Blood specimens with low parasitemia will be forwarded to the CA State Laboratory for Multiplex Real-time PCR for detecting <i>Plasmodium</i> species for speciation of <i>P. falciparum</i> , <i>P. vivax</i> , <i>P. ovale</i> , and <i>P. malariae</i> . The specimen may be forwarded to CDC for other blood parasites per request.
Acceptable Specimen Type(s) and Collection Method	<p>Blood smears: Prepared from fresh whole blood collected by venipuncture within the last hour and before initiating anti-parasitic therapy.</p> <p>Thin Blood Film: Fixed in absolute methanol, allowed to dry, and stained.</p> <p>Thick Blood Film: Thoroughly dried and stained.</p> <p>Include whole blood collected in a tube (EDTA (0.020 g/10 ml of blood) preferred).</p> <p>Heparin (2 mg/10 ml of blood) or sodium citrate (0.050 g/10 ml of blood) may be used as an anticoagulant if trypanosomes or microfilariae are suspected.</p>
Minimum Volume Requested	2 air-dried, stained blood smears (1 thick and 1 thin) and 0.5 mL whole blood.

Transport Medium	Two separate glass slides, each with a frosted end in a slide holder. For the blood specimen, EDTA (lavender-top) tube.
Specimen Labeling	Specimen must be labeled with two identifiers, including patient full name, and at least one other identifier (specimen accession number, date of birth, medical record number); date and time of collection.
Storage & Preservation of Specimen / Shipping Conditions	Slides: Room temperature. Refrigerated OK for transport. EDTA whole blood: Not recommended >24 hours Refrigerated (2-8°C): up to 4 months.
Shipping Instructions	Transport with cold packs to maintain refrigerated temperature. Blood smears can be stored and shipped at room temperature (do not freeze). Ensure microscope slides are shipped in a slide mailer to prevent breakage. Secure the EDTA blood tube (purple top) with parafilm or tape to provide extra protection against leaks. Ship specimens following instructions for Biological Substance – Category B (UN 3373) shipment.
Shipping Address	San Diego Public Health Laboratory ATTN: Specimen Receiving 5540 Overland Ave. San Diego, CA 92123 Phone: 858-325-6400
Turnaround Time	8 hours
Limitations	Blood that has been “milked” from the finger will be diluted with tissue fluids, decreasing the number of parasites per field. If the blood in the tube cools to room temperature and the cap has been removed, several morphological changes of the parasite could occur.
Rejection Criteria	<ol style="list-style-type: none"> 1. Specimens with insufficient or conflicting labelling 2. Specimens that are too old or not stored/transported correctly. 3. Whole Blood: Leaking specimens Specimens with insufficient quantities
Additional Information	None
Contact Information	Bacteriology/Mycology/Parasitology section: 619-917-2144, 858-694-3992, or phslaboratory.hhsa@sdcounty.ca.gov



San Diego County Public Health Laboratory

Jeremy Corrigan, DrPH, HCLD/TS(ABB)
5540 Overland Ave., San Diego, CA 92123
Ph: 858-694-2580
Fax: 619-692-8558



LIVE WELL
SAN DIEGO

Quantiferon TB-Gold Plus
CPT: 86480

TEST INFORMATION	INFORMATION DETAILS
Is this test currently being performed?	Yes
Pre-Approval	No
Supplemental Information Requested	None
Submittal Form	Specimens must be accompanied with a hard copy of the completed SDPHL Test Requisition Form (PDF).
Methodology	Chemiluminescence Immunoassay (CLIA)
Reflex Testing	None
Acceptable Specimen Type(s) and Collection Method	Plasma collected in lithium heparin tubes. Label date and time of blood collection
Minimum Volume Requested	5mL blood
Specimen Labeling	Each specimen must be labeled with at least two unique patient identifiers, e.g., patient full name and date of birth.
Storage & Preservation of Specimen / Shipping Conditions	Following blood collection, keep lithium-heparin tube at room temperature (RT) (17-25°C) for 15 minutes to 3 hours. After holding at RT, tube may be refrigerated between 2-8° for 16-48 hours.
Shipping Instructions	Ship specimens and a hard copy of the completed submittal forms.
Shipping Address	San Diego Public Health Laboratory ATTN: Specimen Receiving 5540 Overland Ave. San Diego, CA 92123 Phone: 858-325-6400

Turnaround Time	5 business days
Limitations	Incubation of blood outside of time and temperature guidelines may lead to false or erroneous results. Blood collected in sodium heparin tubes will not be tested. Less than 5mLs of blood will not be accepted, Do not freeze specimens.
Additional Information	For more information on specimen collection, please call the laboratory.
Contact Information	phslaboratory.hhsa@sdcounty.ca.gov



San Diego County Public Health Laboratory

Jeremy Corrigan, DrPH, HCLD/TS(ABB)
 5540 Overland Ave., San Diego, CA 92123
 Ph: 858-694-2580
 Fax: 619-692-8558



LIVE WELL
 SAN DIEGO

Respiratory 4-Plex (Influenza A/B, Sars-CoV-2, RSV)

TEST INFORMATION	INFORMATION DETAILS
Is this test currently being performed?	Yes
Pre-Approval	Not required
Supplemental Information Requested	No Supplemental information required
Submittal Form	Specimens must be accompanied by a hard copy of the completed SDPHL Test Requisition Form (PDF).
Methodology	Hologic Panther Fusion real-time polymerase chain reaction (RT-PCR)
Reflex Testing	Influenza A/B positive reflexed for subtyping (not for diagnostic purpose)
Acceptable Specimen Type(s) and Collection Method	Nasopharyngeal and nasal swab specimens in Viral Transport Media (VTM)
Minimum Volume Requested	Single swab in 2-3mL VTM
Specimen Labeling	Each specimen must be labeled with at least two unique patient identifiers, e.g., patient full name and date of birth.
Storage & Preservation of Specimen / Shipping Conditions	Transport refrigerated (2-8°C) for up to 7 days. Store frozen if not tested within 7 days
Shipping Instructions	Ship specimens and a hard copy of the completed submittal forms
Shipping Address	<p style="text-align: center;">San Diego Public Health Laboratory ATTN: Specimen Receiving 5540 Overland Ave. San Diego, CA 92123 Phone: 858-325-6400</p>
Turnaround Time	3 days

Limitations	Do not use calcium alginate swabs or swabs with wooden shafts
Additional Information	Interim Guidelines for Collecting and Handling of Clinical Specimens for COVID-19 Testing COVID-19 CDC
Contact Information	phslaboratory.hhsa@sdcounty.ca.gov



San Diego County Public Health Laboratory

Jeremy Corrigan, DrPH, HCLD/TS(ABB)
 5540 Overland Ave., San Diego, CA 92123
 Ph: 858-325-6400

Fax: 858-268-4102



LIVE WELL
 SAN DIEGO

***Salmonella and Shigella Culture and/or PCR –
 Primary Specimen***

TEST INFORMATION	INFORMATION DETAILS
Is this test currently being performed?	Yes
Pre-Approval	Specimens are accepted only in coordination with the San Diego County Epidemiology Unit
Supplemental Information Requested	Specify the specimen number in the series of collections (e.g., '1 of 2', '2 of 2', etc.).
Submittal Form	Specimens must be accompanied by a completed SDPHL Test Requisition. Include the time of specimen collection.
Methodology	Phenotypic Identification, Serogrouping, Matrix-Assisted Laser Desorption/Ionization - Time of Flight Mass Spectrometry (MALDI-TOF MS), Multiplex PCR
Reflex Testing	<i>Salmonella</i> isolates are forwarded to the CA State Laboratory for molecular characterization using Whole Genome Sequencing (WGS) for public health surveillance and epidemiologic investigations only (clinical reports are not issued).
Acceptable Specimen Type(s) and Collection Method	<ol style="list-style-type: none"> 1. Feces in Para-Pak® C & S. 2. Unpreserved, fresh urine or stool specimens submitted within 2 hours of collection. <p>Urine is an acceptable specimen type if testing for <i>S. Typhi</i>. Specimen must be ≤ 5 days old. Specimens from the same patient must be collected ≥ 24 hours apart</p>
Minimum Volume Requested	<p>1 gram or 1 mL</p> <p>Sufficient feces in the Para-Pak® C & S vial will bring the liquid level up to the “fill to here” line.</p>
Transport Medium	Para-Pak® C & S, a modification of Cary-Blair medium.

Specimen Labeling	<ol style="list-style-type: none"> Two identifiers, including patient full name, and at least one other identifier (specimen accession number, date of birth, medical record number) Date and time of collection.
Storage & Preservation of Specimen / Shipping Conditions	Store specimens at room temperature (2-30°C) or at 2-8°C.
Shipping Instructions	Ship specimens following instructions for Biological Substance – Category B (UN 3373) shipment.
Shipping Address	<p style="text-align: center;">San Diego Public Health Laboratory ATTN: Specimen Receiving 5540 Overland Ave. San Diego, CA 92123 Phone: (858) 325-6400</p>
Turnaround Time	5 calendar days
Limitations	None
Rejection Criteria	<ol style="list-style-type: none"> Specimen with insufficient or conflicting labelling Specimens > 5 days old. Leaking specimen
Additional Information	None
Contact Information	Bacteriology/Parasitology/Antimicrobial Resistance section: Main Laboratory: 858-325-6459 Supervisor: Paul Temprendola (Cell): 619-917-2144 phslaboratory.hhsa@sdcountry.ca.gov



San Diego County Public Health Laboratory

Jeremy Corrigan, DrPH, HCLD/TS(ABB)
 5540 Overland Ave., San Diego, CA 92123
 Ph: 858-325-6400
 Fax: 858-268-4102



LIVE WELL
 SAN DIEGO

Salmonella Identification and Serogrouping

TEST INFORMATION	INFORMATION DETAILS
Is this test currently being performed?	Yes
Pre-Approval	No
Supplemental Information Requested	None
Submittal Form	Specimens must be accompanied by a completed SDPHL Test Requisition Form SD County Test Requisition Updated 07.23.2024.pdf (sandiegocounty.gov)
Methodology	Phenotypic Identification, Serogrouping, Matrix-Assisted Laser Desorption/Ionization - Time of Flight Mass Spectrometry (MALDI-TOF MS)
Reflex Testing	<i>Salmonella</i> isolates are forwarded to the CA State Laboratory for molecular characterization using Whole Genome Sequencing (WGS) for public health surveillance and epidemiologic investigations only (clinical reports are not issued).
Acceptable Specimen Type(s) and Collection Method	Pure <i>Salmonella</i> culture isolate
Minimum Volume Requested	Viable growth should be present on the subculture
Transport Medium	Isolates should be subcultured prior to submission on nonselective nutrient agar (e.g., trypticase soy or heart infusion slant) in leak-proof tube with a screw cap closure.
Specimen Labeling	Two identifiers, including patient full name, and at least one other identifier (specimen accession number, date of birth, medical record number).

Storage & Preservation of Specimen / Shipping Conditions	<p>Grow fresh subculture under appropriate conditions on nonselective nutrient agar slant and verify purity prior to shipping.</p> <p>Isolates may be stored and shipped under refrigeration or ambient temperature to maintain viability. Do not freeze or send frozen cultures.</p>
Shipping Instructions	<p>Ship isolates at ambient temperature (15-25° C) or with cold packs; do not freeze.</p> <p>Ensure that culture isolates are sent in tubes sealed with parafilm or tape for extra leak protection.</p> <p>Ship specimens following instructions for Biological Substance – Category B (UN 3373) shipment.</p>
Shipping Address	<p style="text-align: center;">San Diego Public Health Laboratory ATTN: Specimen Receiving 5540 Overland Ave. San Diego, CA 92123 Phone: (858) 325-6400</p>
Turnaround Time	<p style="text-align: center;">5 calendar days</p>
Limitations	<p>Unable to complete testing if the submitted culture is overgrown by bacterial and/or fungal contaminants or if the culture is non-viable.</p>
Rejection Criteria	<ol style="list-style-type: none"> 1. Submission with insufficient or conflicting labelling 2. Mixed/contaminated culture 3. Leaking specimen 4. Isolates that are non-viable 5. Agar plate
Additional Information	<p style="text-align: center;">None</p>
Contact Information	<p>Bacteriology/Parasitology/Antimicrobial Resistance section: Main Laboratory: 858-325-6459 Supervisor: Paul Tempredola (Cell): 619-917-2144 phslaboratory.hhsa@sdcounty.ca.gov</p>



San Diego County Public Health Laboratory

Jeremy Corrigan, DrPH, HCLD/TS(ABB)
 5540 Overland Ave., San Diego, CA 92123
 Ph: 858-325-6400
 Fax: 858-268-4102



LIVE WELL
 SAN DIEGO

Shiga Toxins EIA & STEC Isolation – Primary Specimen

TEST INFORMATION	INFORMATION DETAILS
Is this test currently being performed?	Yes
Pre-Approval	Specimens are accepted only in coordination with the San Diego County Epidemiology Unit
Supplemental Information Requested	None
Submittal Form	<p>Specimens must be accompanied by a completed SDPHL Test Requisition. SD County Test Requisition Updated 07.23.2024.pdf (sandiegocounty.gov) Include the time of specimen collection. Specify the following:</p> <ol style="list-style-type: none"> 1. Specimen number in the series of collections (e.g., '1 of 2', '2 of 2', etc.). 2. Time of Collection
Methodology	Enzyme Immunoassay
Reflex Testing	<ol style="list-style-type: none"> 1. If Shiga toxin is detected by EIA, then Culture, Phenotypic Identification, and Serogrouping are performed. 2. Shiga toxin-producing <i>Escherichia coli</i> (STEC) isolates are forwarded to the CA State laboratory for serogrouping, serotyping, and/or whole genome sequencing (WGS). WGS is for public health surveillance and epidemiologic investigations only (clinical reports are not issued).
Acceptable Specimen Type(s) and Collection Method	<ol style="list-style-type: none"> 1. Stool in Para-Pak® C & S. 2. Unpreserved stool specimens submitted within 2 hours of collection. <p>Specimen must be ≤ 4 days old.</p> <p>Specimens from the same patient must be collected ≥ 24 hours apart.</p> <p>Collect in clean, dry container and then transfer stool into a C&S transport medium. Fluid level should reach line on vial.</p>

Minimum Volume Requested	1 gram or 1 mL. Sufficient feces in the Para-Pak® C & S vial will bring the liquid level up to the “fill to here” line. For solid stool, this is approximately the size of a 40 mm diameter piece.
Transport Medium	Para-Pak® C & S, a modification of Cary-Blair medium.
Specimen Labeling	<ol style="list-style-type: none"> 1. Two identifiers, including patient full name, and at least one other identifier (specimen accession number, date of birth, medical record number) 2. Date and time of collection.
Storage & Preservation of Specimen / Shipping Conditions	Store specimens at room temperature (2-30°C) or at 2-8°C.
Shipping Instructions	Ship specimens following instructions for Biological Substance – Category B (UN 3373) shipment.
Shipping Address	<p>San Diego Public Health Laboratory ATTN: Specimen Receiving 5540 Overland Ave. San Diego, CA 92123 Phone: 858-325-6400</p>
Turnaround Time	5 business days
Limitations	A negative test result does not preclude the possibility of the presence of Shiga toxins in the specimen which may occur if the level of antigen is below the detection limit of the test.
Rejection Criteria	<ol style="list-style-type: none"> 1. Specimen with insufficient or conflicting labelling 2. Specimens > 4 days old. 3. Leaking specimen 4. Specimens in 10% formalin or other fixatives
Additional Information	None
Contact Information	<p>Bacteriology/Parasitology/Antimicrobial Resistance section: Main Laboratory: 858-325-6459 Supervisor: Paul Temprendola (Cell): 619-917-2144 phslaboratory.hhsa@sdcountry.ca.gov</p>



San Diego County Public Health Laboratory

Jeremy Corrigan, DrPH, HCLD/TS(ABB)
 5540 Overland Ave., San Diego, CA 92123
 Ph: 858-325-6400
 Fax: 858-268-4102



LIVE WELL
 SAN DIEGO

***Shigella* Identification and Serogrouping**

TEST INFORMATION	INFORMATION DETAILS
Is this test currently being performed?	Yes
Pre-Approval	No
Supplemental Information Requested	None
Submittal Form	Specimens must be accompanied by a completed SDPHL Test Requisition Form SD County Test Requisition Updated 07.23.2024.pdf sandiegocounty.gov
Methodology	Phenotypic Identification, Serogrouping, Matrix-Assisted Laser Desorption/Ionization - Time of Flight Mass Spectrometry (MALDI-TOF MS)
Reflex Testing	None
Acceptable Specimen Type(s) and Collection Method	Pure <i>Shigella</i> culture isolate
Minimum Volume Requested	Viable growth should be present on the subculture.
Transport Medium	Isolates should be subcultured prior to submission on nonselective nutrient agar (e.g., trypticase soy or heart infusion slant) in leak-proof tube with a screw cap closure.
Specimen Labeling	Two identifiers, including patient full name, and at least one other identifier (specimen accession number, date of birth, medical record number)
Storage & Preservation of Specimen / Shipping Conditions	Grow fresh subculture under appropriate conditions on nonselective nutrient agar slant and verify purity prior to shipping. Isolates may be stored and shipped under refrigeration or ambient temperature to maintain viability. Do not freeze or send frozen cultures.

Shipping Instructions	<p>Ship isolates at ambient temperature (15-25° C) or with cold packs; do not freeze.</p> <p>Ensure that culture isolates are sent in tubes sealed with parafilm or tape for extra leak protection.</p>
	Ship specimens following instructions for Biological Substance – Category B (UN 3373) shipment.
Shipping Address	<p>San Diego Public Health Laboratory ATTN: Specimen Receiving 5540 Overland Ave. San Diego, CA 92123 Phone: 858-325-6400</p>
Turnaround Time	5 calendar days
Limitations	Unable to identify if submitted culture is overgrown by bacterial and/or fungal contaminants or if the culture is non-viable.
Rejection Criteria	<ol style="list-style-type: none"> 1. Submission with insufficient or conflicting labelling 2. Mixed/contaminated culture 3. Leaking specimen 4. Isolates that are non-viable 5. Agar plate
Additional Information	None
Contact Information	<p>Bacteriology/Parasitology/Antimicrobial Resistance section: Main Laboratory: 858-325-6459 Supervisor: Paul Temprendola (Cell): 619-917-2144 phslaboratory.hhsa@sdcounty.ca.gov</p>



San Diego County Public Health Laboratory

Jeremy Corrigan, DrPH, HCLD/TS(ABB)
 5540 Overland Ave., San Diego, CA 92123
 Ph: 858-325-6400
 Fax: 858-268-4102



LIVE WELL
 SAN DIEGO

STEC Isolation for Enrichment Broth

TEST INFORMATION	INFORMATION DETAILS
Is this test currently being performed?	Yes
Pre-Approval	No
Supplemental Information Requested	None
Submittal Form	Specimens must be accompanied by a completed SDPHL Test Requisition Form SD County Test Requisition Updated 07.23.2024.pdf (sandiegocounty.gov)
Methodology	Isolation, Culture, Phenotypic Identification, Serogrouping, Enzyme Immunoassay
Reflex Testing	Shiga toxin-producing <i>Escherichia coli</i> (STEC) isolates are forwarded to the CA State laboratory for serogrouping, serotyping, and/or whole genome sequencing (WGS). WGS is for public health surveillance and epidemiologic investigations only (clinical reports are not issued).
Acceptable Specimen Type(s) and Collection Method	GN or MAC Broth positive for Shiga toxin, taken from patient specimen collected within the last 14 days.
Minimum Volume Requested	5 mL
Transport Medium	GN or MAC Broth
Specimen Labeling	Each specimen must be labeled with at least two unique patient identifiers, e.g., patient full name and date of birth.
Storage & Preservation of Specimen / Shipping Conditions	2-8°C

Shipping Instructions	<p>Transport specimens refrigerated using frozen gel packs. Do not use wet or dry ice.</p> <p>Ship specimens following instructions for Biological Substance – Category B (UN 3373) shipment.</p>
Shipping Address	<p>San Diego Public Health Laboratory ATTN: Specimen Receiving 5540 Overland Ave. San Diego, CA 92123 Phone: 858-325-6400</p>
Turnaround Time	10 business days
Limitations	A negative Shiga toxin test result does not preclude the possibility of the presence of Shiga toxins in the specimen which may occur if the level of antigen is below the detection limit of the test.
Additional Information	None
Rejection Criteria	<ol style="list-style-type: none"> 1. Specimen with insufficient or conflicting labelling 2. Leaking specimen
Contact Information	<p>Bacteriology/Parasitology/Antimicrobial Resistance section: Main Laboratory: 858-325-6459 Supervisor: Paul Temprendola (Cell): 619-917-2144 phslaboratory.hhsa@sdcounty.ca.gov</p>



San Diego County Public Health Laboratory

Jeremy Corrigan, DrPH, HCLD/TS(ABB)
 5540 Overland Ave., San Diego, CA 92123
 Ph: 858-694-2580
 Fax: 619-692-8558



LIVE WELL
 SAN DIEGO

Syphilis Reverse Algorithm

CPT: 86780, 86593, 86780

TEST INFORMATION	INFORMATION DETAILS
Is this test currently being performed?	Yes
Pre-Approval	No
Supplemental Information Requested	None
Submittal Form	Specimens must be accompanied with a hard copy of the completed SDPHL Test Requisition Form (PDF).
Methodology	Chemiluminescent Microparticle Immunoassay (CMIA)
Reflex Testing	<ul style="list-style-type: none"> Rapid Plasma Reagin (RPR) Treponema Pallidum Particle Agglutination (TP-PA)
Acceptable Specimen Type(s) and Collection Method	Serum collected in Serum Separator Tubes or red top tubes
Minimum Volume Requested	2mL
Specimen Labeling	Each specimen must be labeled with at least two unique patient identifiers, e.g., patient full name and date of birth.
Storage & Preservation of Specimen / Shipping Conditions	Serum specimens should be stored for no longer than 3 days at room temperature or 7 days at 2 to 8°C from collection. If storage period is anticipated for greater than 7 days, the specimen should be removed from the clot, red blood cells, or separator gel, and stored frozen at -20°C or colder.
Shipping Instructions	Ship specimens and a hard copy of the completed submittal forms.
Shipping Address	San Diego Public Health Laboratory ATTN: Specimen Receiving 5540 Overland Ave. San Diego, CA 92123 Phone: 858-325-6400

Turnaround Time	7 business days
Limitations	Specimens that are hemolyzed, pooled, heat inactivated, or having gross microbial contamination will not be tested.
Additional Information	For more information on specimen collection, please call the laboratory.
Contact Information	phslaboratory.hhsa@sdcounty.ca.gov



San Diego County Public Health Laboratory

Jeremy Corrigan, DrPH, HCLD/TS(ABB)
5540 Overland Ave., San Diego, CA 92123
Ph: 858-694-2580
Fax: 619-692-8558



LIVE WELL
SAN DIEGO

Trichomonas vaginalis PCR
CPT: 87661

TEST INFORMATION	INFORMATION DETAILS
Is this test currently being performed?	Yes
Pre-Approval	No
Supplemental Information Requested	Not Requested
Submittal Form	Specimens must be accompanied with a hard copy of the completed SDPHL Test Requisition Form (PDF).
Methodology	Transcription Mediated Amplification
Reflex Testing	None
Acceptable Specimen Type(s) and Collection Method	<ul style="list-style-type: none">• Male and Female urine specimens• Endocervical swabs• Vaginal swabs (patient or clinician collected)• Vaginal swab (clinical collected)
Collection Device	<ul style="list-style-type: none">• Aptima Urine collection device (2mL urine)• Aptima Multi-test Collection device (swabs)
Specimen Labeling	Each specimen must be labeled with at least two unique patient identifiers, e.g., patient full name and date of birth.
Storage & Preservation of Specimen / Shipping Conditions	Specimens to be transported between 2-8°C
Shipping Instructions	Ship specimens and a hard copy of the completed submittal forms.
Shipping Address	San Diego Public Health Laboratory ATTN: Specimen Receiving 5540 Overland Ave. San Diego, CA 92123 Phone: 858-325-6400
Turnaround Time	7 business days

Limitations	Urine specimens filled above or below fill lines will not be tested. Multi-test collection devices missing swabs or containing more than one swab will not be tested.
Additional Information	For more information on specimen collection, please call the laboratory.
Contact Information	phslaboratory.hhsa@sdcounty.ca.gov



San Diego County Public Health Laboratory

Jeremy Corrigan, DrPH, HCLD/TS(ABB)
 5540 Overland Ave., San Diego, CA 92123
 Ph: 858-325-6400
 Fax: 858-268-4102



LIVE WELL
 SAN DIEGO

Vibrio cholerae Identification

TEST INFORMATION	INFORMATION DETAILS
Is this test currently being performed?	Yes
Pre-Approval	No
Supplemental Information Requested	None
Submittal Form	Specimens must be accompanied by a completed SDPHL Test Requisition Form. SD County Test Requisition Updated 07.23.2024.pdf sandiegocounty.gov
Methodology	Phenotypic Identification
Reflex Testing	<i>Vibrio cholerae</i> isolates are forwarded to the CA State Laboratory for molecular characterization using Whole Genome Sequencing (WGS) for public health surveillance and epidemiologic investigations only (clinical reports are not issued).
Acceptable Specimen Type(s) and Collection Method	Pure Isolate
Minimum Volume Requested	Viable growth should be present on the subculture
Transport Medium	Nonselective nutrient agar or similar agar medium, in leak-proof tubes with screw cap closures.
Specimen Labeling	Two identifiers, including patient full name, and at least one other identifier (specimen accession number, date of birth, medical record number)
Storage & Preservation of Specimen / Shipping Conditions	Store and ship at ambient temperature.

Shipping Instructions	<p>Ship isolates at ambient temperature on nonselective nutrient agar or similar agar medium, in leak-proof tubes with screw cap closures.</p> <p>Ship specimens and a hard copy of the completed submittal forms.</p>
	Ship specimens following instructions for Biological Substance – Category B (UN 3373) shipment.
Shipping Address	<p style="text-align: center;">San Diego Public Health Laboratory ATTN: Specimen Receiving 5540 Overland Ave. San Diego, CA 92123 Phone: (858) 325-6400</p>
Turnaround Time	5 business days
Limitations	None
Rejection Criteria	<ol style="list-style-type: none"> 1. Submission with insufficient or conflicting labelling 2. Mixed/contaminated culture 3. Leaking specimen 4. Isolates that are non-viable 5. Agar plate received
Additional Information	None
Contact Information	<p>Bacteriology/Parasitology/Antimicrobial Resistance section: Main Laboratory: 858-325-6459 Supervisor: Paul Temprendola (Cell): 619-917-2144 phslaboratory.hhsa@sdcounty.ca.gov</p>



San Diego County Public Health Laboratory

Jeremy Corrigan, DrPH, HCLD/TS(ABB)
 5540 Overland Ave., San Diego, CA 92123
 Ph: 858-325-6400
 Fax: 858-268-4102



LIVE WELL
 SAN DIEGO

Vibrio, Aeromonas, and Related Organisms Identification

TEST INFORMATION	INFORMATION DETAILS
Is this test currently being performed?	Yes
Pre-Approval	No
Supplemental Information Requested	None
Submittal Form	Specimens must be accompanied by a completed SDPHL Test Requisition Form. SD County Test Requisition Updated 07.23.2024.pdf (sandiegocounty.gov)
Methodology	Phenotypic Identification, Matrix-Assisted Laser Desorption/Ionization - Time of Flight Mass Spectrometry (MALDI-TOF MS)
Reflex Testing	None
Acceptable Specimen Type(s) and Collection Method	Pure Isolate
Minimum Volume Requested	Viable growth should be present on the subculture
Transport Medium	Nonselective nutrient agar or similar agar medium, in leak-proof tubes with screw cap closures.
Specimen Labeling	Two identifiers, including patient full name, and at least one other identifier (specimen accession number, date of birth, medical record number)
Storage & Preservation of Specimen / Shipping Conditions	Store and ship at ambient temperature

Shipping Instructions	<p>Ship isolates at ambient temperature on nonselective nutrient agar or similar agar medium, in leak-proof tubes with screw cap closures.</p> <p>Ship specimens and a hard copy of the completed submittal forms.</p> <p>Ship specimens following instructions for Biological Substance – Category B (UN 3373) shipment.</p>
Shipping Address	<p style="text-align: center;">San Diego Public Health Laboratory ATTN: Specimen Receiving 5540 Overland Ave. San Diego, CA 92123 Phone: (858) 325-6400</p>
Turnaround Time	<p style="text-align: center;">5 business days</p>
Limitations	<p style="text-align: center;">None</p>
Rejection Criteria	<ol style="list-style-type: none"> 1. Submission with insufficient or conflicting labelling 2. Mixed/contaminated culture 3. Leaking specimen 4. Isolates that are non-viable 5. Agar plate received
Additional Information	<p style="text-align: center;">None</p>
Contact Information	<p>Bacteriology/Parasitology/Antimicrobial Resistance section: Main Laboratory: 858-325-6459 Supervisor: Paul Temprendola (Cell): 619-917-2144 phslaboratory.hhsa@sdcounty.ca.gov</p>



San Diego County Public Health Laboratory

Jeremy Corrigan, DrPH, HCLD/TS(ABB)
 5540 Overland Ave., San Diego, CA 92123
 Ph: 858-325-6400
 Fax: 858-268-4102



LIVE WELL
 SAN DIEGO

***Yersinia* (non-*Y. pestis*) and other Enterobacterales Identification**

TEST INFORMATION	INFORMATION DETAILS
Is this test currently being performed?	Yes
Pre-Approval	No
Supplemental Information Requested	None
Submittal Form	Specimens must be accompanied by a completed SDPHL Test Requisition Form. SD County Test Requisition Updated 07.23.2024.pdf (sandiegocounty.gov)
Methodology	Phenotypic Identification, Matrix-Assisted Laser Desorption/Ionization - Time of Flight Mass Spectrometry (MALDI-TOF MS)
Reflex Testing	None
Acceptable Specimen Type(s) and Collection Method	Pure Isolate
Minimum Volume Requested	Viable growth should be present on the subculture
Transport Medium	Nonselective nutrient agar or similar agar medium, in leak-proof tubes with screw cap closures.
Specimen Labeling	Two identifiers, including patient full name, and at least one other identifier (specimen accession number, date of birth, medical record number)
Storage & Preservation of Specimen / Shipping Conditions	Store and ship at ambient temperature

Shipping Instructions	<p>Ship isolates at ambient temperature on nonselective nutrient agar or similar agar medium, in leak-proof tubes with screw cap closures.</p> <p>Ship specimens and a hard copy of the completed submittal forms.</p> <p>Ship specimens following instructions for Biological Substance – Category B (UN 3373) shipment.</p>
Shipping Address	<p style="text-align: center;">San Diego Public Health Laboratory ATTN: Specimen Receiving 5540 Overland Ave. San Diego, CA 92123 Phone: (858) 325-6400</p>
Turnaround Time	<p style="text-align: center;">5 business days</p>
Limitations	<p style="text-align: center;">None</p>
Rejection Criteria	<ol style="list-style-type: none"> 1. Submission with insufficient or conflicting labelling 2. Mixed/contaminated culture 3. Leaking specimen 4. Isolates that are non-viable 5. Agar plate received
Additional Information	<p style="text-align: center;">None</p>
Contact Information	<p>Bacteriology/Parasitology/Antimicrobial Resistance section: Main Laboratory: 858-325-6459 Supervisor: Paul Temprendola (Cell): 619-917-2144 phslaboratory.hhsa@sdcounty.ca.gov</p>

I. APPENDICES

Appendix 1: Packaging and Labeling

Transportation of potentially infectious substances is specifically regulated, to protect those handling and receiving the shipment. Follow federal regulations for transporting hazardous materials. If samples are to be transported to the Public Health Laboratory by a courier service, Category B samples can be put in mailing cylinders and placed inside a sealed cooler or similar carrier and hand-delivered. Cooler should have proper markings, UN3373 label, and a biohazard label. If specimens are to be shipped by air or postal service, follow proper regulations for shipping of Category A or Category B Infectious Substances (depending on agent). The watertight primary collection or sample tube must be wrapped (individually, in the case of multiple tubes) in bubble pack with absorbent material enclosed sufficient to absorb any spilled material, and placed within a secondary watertight package. The secondary package must be placed within a rigid container capable of withstanding standardized crush tests and then be properly labeled. Figures 1 and 2 illustrates some examples.

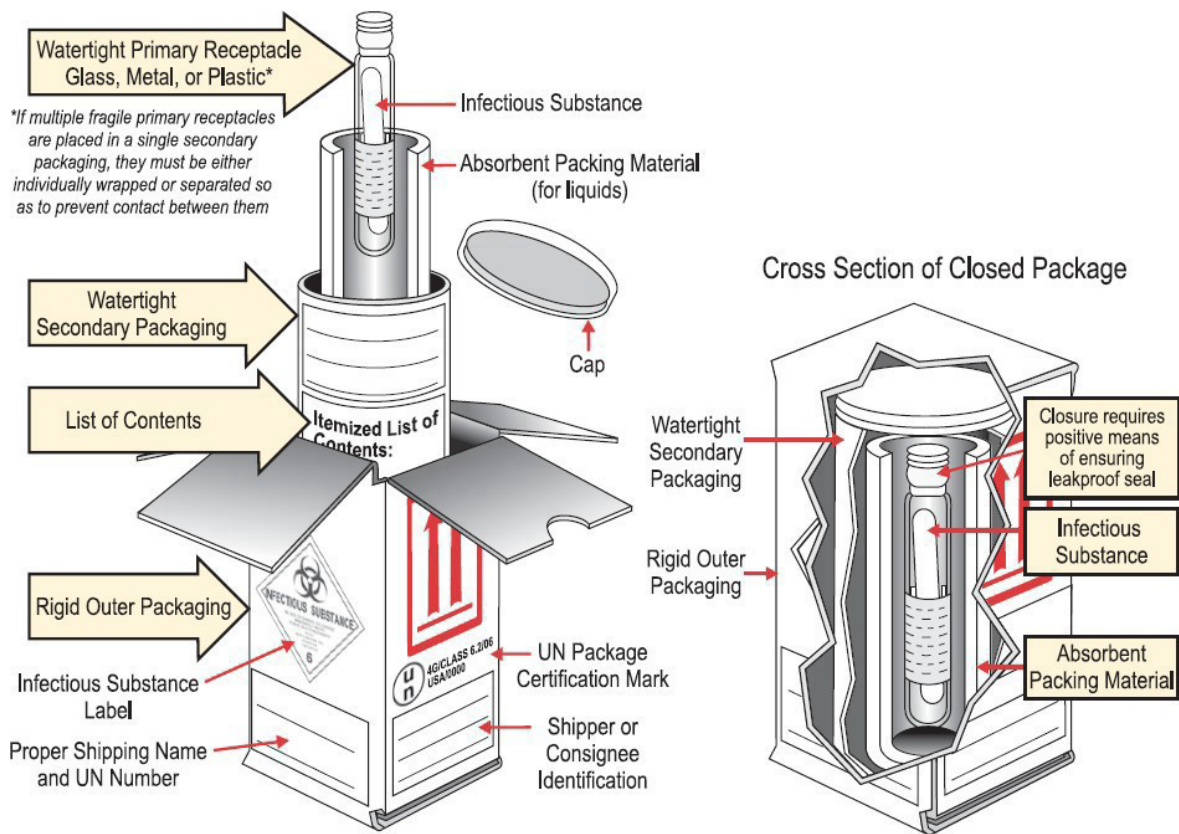

Figure 1. Category A Packing and Labeling from Department of Transportation

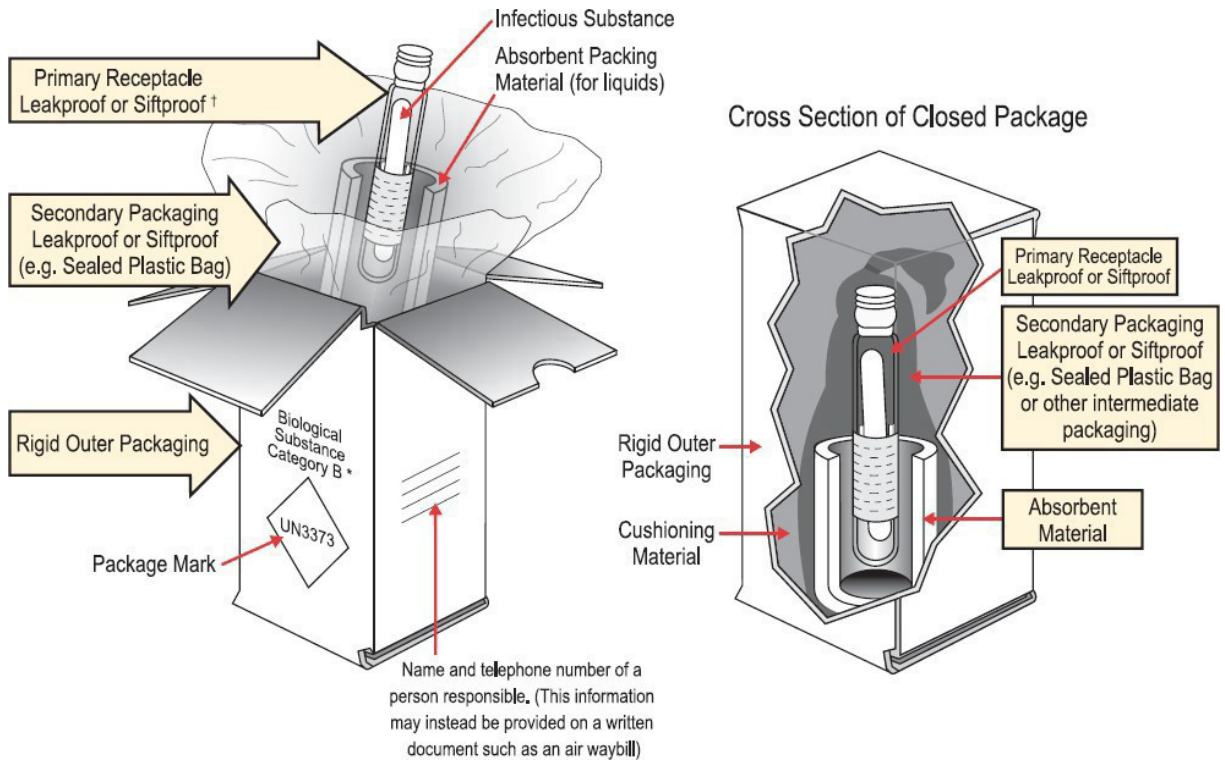
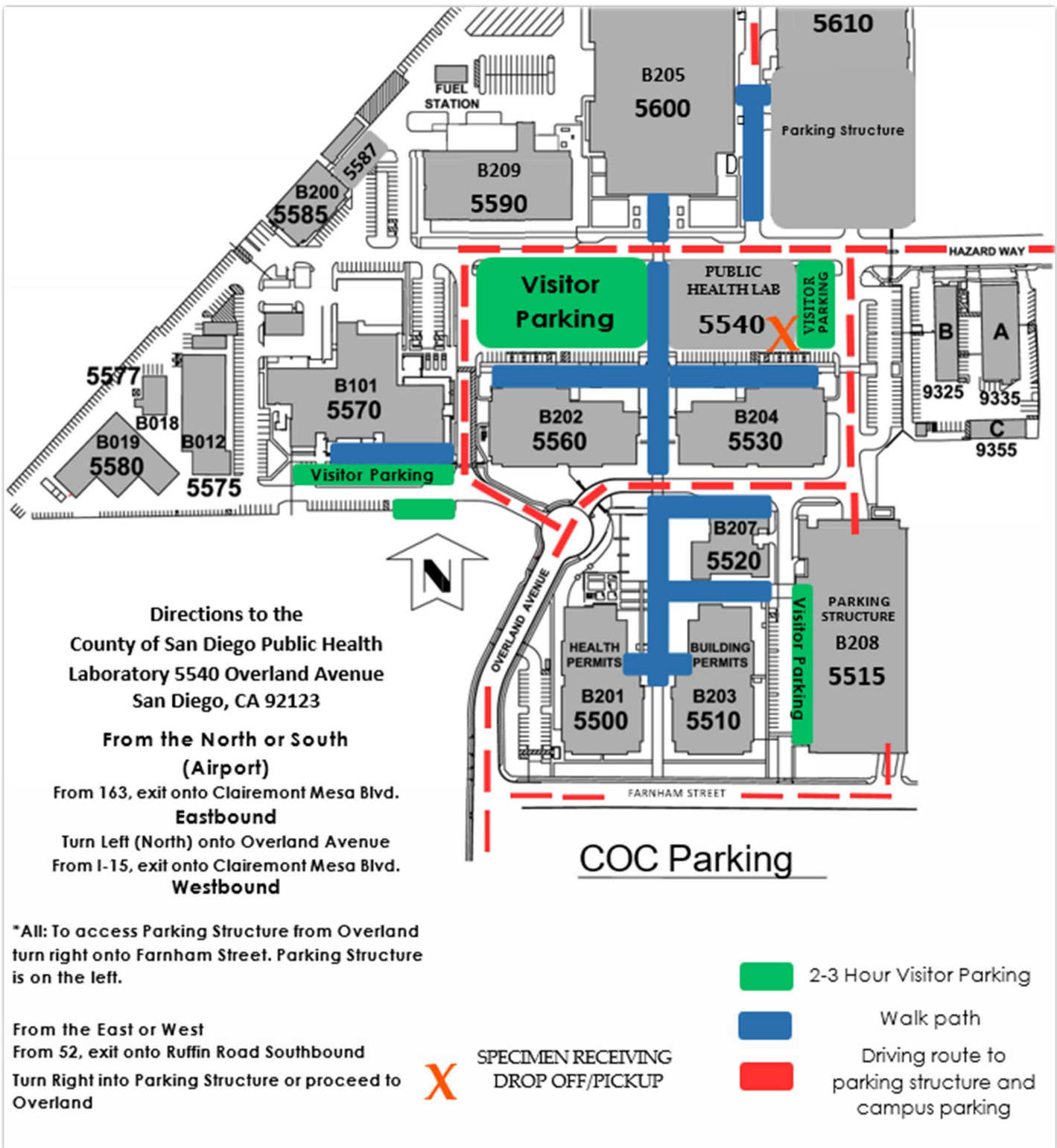

Figure 2. Category B Packing and Labeling from Department of Transportation

County of San Diego County Operations Center





San Diego County Public Health Laboratory

5540 Overland Avenue, San Diego, CA 92123
Jeremy Corrigan, DrPH, HCLD/TS(ABB)
Phone:(858) 325-6400 | Fax:(858) 268-4102
CLIA# 05D2324555

THIS SPACE IS RESERVED FOR
PUBLIC HEALTH LAB USE ONLY

Test Requisition Form

Patient Information <small>(*) denotes required information</small>			Submitter Information <small>New submitters must complete a Client Agreement Form. Results will <u>not</u> be released until the form is submitted.</small>	
*Last Name	*First Name	Middle Name	FIRST NAME LAST NAME *Ordering Physician *National Provider ID (NPI)	
*DOB	*Pregnancy Status	*Gender <input type="checkbox"/> Male <input type="checkbox"/> Female <input type="checkbox"/> Transgender M/F <input type="checkbox"/> Decline <input type="checkbox"/> Transgender F/M <input type="checkbox"/> Unknown		
*Address			*Facility Name	
*City, State, Zip			*Address	
*Phone	MRN/ID#		*Phone	Email
*Race <input type="checkbox"/> American Indian/ Alaska Native <input type="checkbox"/> Asian Pacific Islander <input type="checkbox"/> Black/African American <input type="checkbox"/> White <input type="checkbox"/> Unknown <input type="checkbox"/> Decline			*Alternate Contact <small>(ie. PHN/CDI/Epi)</small>	
*Ethnicity <input type="checkbox"/> Hispanic/ Latino <input type="checkbox"/> Not Hispanic/ Latino <input type="checkbox"/> Unknown <input type="checkbox"/> Decline			Original Submitter <small>(if applicable)</small>	
For More Information on Extended Race and Ethnicity Click Here . Extended Race Extended Ethnicity			Clinical Information <small>(ie. date of onset/exposure, travel history, previous lab results)</small> Case ID	

Specimen Information

SUBMIT ONE TEST REQUISITION FORM PER SPECIMEN SOURCE

Collection Information	*Specimen Source					
*Date	<input type="checkbox"/> Blood	<input type="checkbox"/> Urethra	<input type="checkbox"/> Stool	<input type="checkbox"/> BAL	<input type="checkbox"/> Nasal	<input type="checkbox"/> Aspirate <small>(specify type):</small>
Time	<input type="checkbox"/> Serum	<input type="checkbox"/> Vaginal	<input type="checkbox"/> Rectal	<input type="checkbox"/> Nasopharynx	<input type="checkbox"/> CSF	<input type="checkbox"/> Body fluid <small>(specify type):</small>
Collected By	<input type="checkbox"/> Plasma	<input type="checkbox"/> Vaginal <small>(self collected)</small>	<input type="checkbox"/> Throat	<input type="checkbox"/> Buccal	<input type="checkbox"/> Tissue, Skin, Nail <small>(specify location):</small>	
Collection series #: ___ of ___	<input type="checkbox"/> Urine	<input type="checkbox"/> Cervix	<input type="checkbox"/> Sputum <small>Induced</small>	<input type="checkbox"/> Oropharynx	<input type="checkbox"/> Other <small>(specify):</small>	

*Test(s) Requested

Bacteriology	Parasitology	Molecular
<input type="checkbox"/> Aerobic Bacterial Culture	<input type="checkbox"/> Ova and Parasite Exam	<input type="checkbox"/> Chlamydia/Gonorrhea NAAT
<input type="checkbox"/> Aerobic Bacterial Identification <small>(*Attach worksheet/results)</small>	<input type="checkbox"/> Cryptosporidium DFA <input type="checkbox"/> Giardia DFA	<input type="checkbox"/> Trichomonas NAAT
<input type="checkbox"/> N. gonorrhoeae Culture <input type="checkbox"/> GC Smear	<input type="checkbox"/> Malaria Confirmation	<input type="checkbox"/> HIV-1 Viral Load
<input type="checkbox"/> Enteric Pathogens ID <small>(specify organism):</small> <small>(*Attach worksheet/results)</small>	<input type="checkbox"/> Blood Parasite Identification	<input type="checkbox"/> HSV 1/2 PCR
<input type="checkbox"/> Enteric Pathogens Culture <small>(specify organism):</small>	<input type="checkbox"/> Coccidian Identification <small>(Cyclospora sp. and Isospora sp.)</small>	<input type="checkbox"/> Resp. Panel <input type="checkbox"/> HCW <input type="checkbox"/> Resident <input type="checkbox"/> Other
<input type="checkbox"/> Rule Out <small>(specify organism):</small> <small>(*Attach worksheet/results)</small>	<input type="checkbox"/> Send Out <small>(specify test):</small>	<input type="checkbox"/> COVID-19-WGS Ct Value: <small>(*Enter Ct value of specimen)</small>
	<input type="checkbox"/> SARS-CoV-2 IgG	<input type="checkbox"/> Send Out <small>(specify test):</small>
	<input type="checkbox"/> HIV- 1/2 Ag/Ab Reflex Panel	<input type="checkbox"/> Hepatitis A PCR <small>(pre-approved only)¹</small>
Mycobacteriology	<input type="checkbox"/> Syphilis Reflex Panel <small>(reverse algorithm)</small>	<input type="checkbox"/> Influenza PCR Previous test results <input type="checkbox"/> A <input type="checkbox"/> B
<input type="checkbox"/> AFB Smear. Culture. Susceptibility	<input type="checkbox"/> QuantiFERON-TB <input type="checkbox"/> *Not Incubated <input type="checkbox"/> *Incubated Time in/out: _____/_____/_____	<input type="checkbox"/> Outpatient <input type="checkbox"/> Hospitalized <input type="checkbox"/> ICU
<input type="checkbox"/> MTB Complex Susceptibility Only	<input type="checkbox"/> Hepatitis B Core Ab Total Reflex Panel	<input type="checkbox"/> Outbreak <input type="checkbox"/> Inmate <input type="checkbox"/> Fatal
<input type="checkbox"/> GeneXpert MTB/RIF PCR	<input type="checkbox"/> Hepatitis C Ab Reflex Panel	Outbreak case#
<input type="checkbox"/> MTB complex Isolate (Title 17) <small>(*Attach worksheet/results)</small>	<input type="checkbox"/> Measles IgG	<input type="checkbox"/> Mumps PCR <small>(pre-approved only)²</small>
<input type="checkbox"/> Other Test(s) <small>Consult with Lab</small>		<input type="checkbox"/> Measles PCR <small>(pre-approved only)²</small>
Enter Test Name Here		<input type="checkbox"/> Norovirus PCR <small>(pre-approved only)¹</small>
		<input type="checkbox"/> Mpox Rule Out Clade I <small>(pre-approved only)¹</small>
		<input type="checkbox"/> SDPHL Dengue PCR <small>(pre-approved only)¹</small>

1-This test must be approved by the San Diego County Epidemiology Program, please call 619-692-8499. 2-This test must be approved by the San Diego County Immunization Program, please call 866-358-2966 option 5. Submitters may incur fees for testing, in accordance with the board-approved fee schedule available on the San Diego County Public Health Laboratory website.

Specimens received at the San Diego County Public Health Laboratory located at 5540 Overland Avenue, San Diego, CA 92123, may be tested at one of the following CLIA-certified facilities:

San Diego County Public Health Laboratory (NEW)
5540 Overland Avenue, San Diego, CA 92123
CLIA# 05D2324555

San Diego County Public Health Laboratory (COOP)
5570 Overland Avenue, San Diego, CA 92123
CLIA# 05D0060808

San Diego County Public Health Modular Laboratory
5587 Overland Avenue, San Diego, CA 92123
CLIA# 05D2274872



San Diego County Public Health Laboratory

5540 Overland Avenue, San Diego, CA 92123
 Phone: (858) 325-6400 | Fax: (858) 268-4102



LIVE WELL
 SAN DIEGO

CLIENT AGREEMENT FORM

This agreement should be completed in full by parties who are receiving personal health information to ensure test results are sent in a secure environment. The recipient agrees to comply with the Health Insurance Portability and Accountability Act (HIPAA) provision. Additionally, the recipient will protect the confidentiality of emailed or faxed test results, use a fax machine in a secured area, and comply with the confidentiality notice below. If the recipient is in agreement, please provide the information below on an annual basis or if any changes occur to accurate up-to-date communication and method of delivery.

Confidentiality notice: The documents accompanying this transmission may contain confidential health information that is privileged, confidential and exempt from disclosure under law. This information is intended only for the use of the entity or individual named above. The authorized recipient of this information is prohibited from disclosing this information to any other party unless required to do so by law or regulation and is required to destroy the information after its stated need has been fulfilled.

If you are not the intended recipient, you are hereby notified that any disclosure, copying, distribution, or action taken in reliance on the contents of these documents is strictly prohibited. If you have received this information in error, please notify the sender immediately and arrange for the return or destruction of these documents.

1	Facility Information		
	Facility Name:		Phone Number:
	Address (Street, City, State, Zip):		
2	Secure Delivery Information		
	Method of Delivery: <input type="checkbox"/> Email Address <input type="checkbox"/> Fax Machine or System		
	Email (preferred) or Fax:		
	Fax location address if different than above:		
3	Contact Information		
	Name:		Title:
	Phone Number:	Email:	
4	Authorized Official Information		
	Name:		Title:
	Phone Number:	Email:	
	The undersigned certifies that the forgoing information is correct and agrees to abide by all terms and conditions contained in this agreement.		
	Authorized Official Signature:		Date:
	Once completed, email to Labs.HHSA@sdcounty.ca.gov or fax to (858) 268-4102.		
Public Health Laboratory Administration Use Only			
Clerical Section			
Email or Fax Number verified? Yes No		Verified By:	Upload Date:
LIMS Section			
Entry Date:	Client ID:	Expiration Date:	

Appendix 4: Client Agreement Form (cont.)

1. Facility Information
 - a. **Facility Name** refers to the specific name given to a physical location where the specimen was obtained and sent from. The facility name must match the name used on the test requisition form.
 - b. **Address** for the facility includes street name, city, state, and postal/zip code.
 - c. **Phone Number** refers to the facility's general, front desk, or laboratory phone number.
2. Secure Delivery Information
 - a. **Method of Delivery** refers to the preferred selection of secure environment (email or fax) to receive test results.
 - b. **Email or Fax** refers to the email address or fax number - starting with area code. Email is preferred.
 - c. **Fax location address if different than above** refers to a different location where the fax machine is.
3. Contact Information
 - a. **Name** of the designated or primary contact for technical inquiries and notifications regarding the specimen received or test(s) requested.
 - b. **Title** of position or role within facility.
 - c. **Phone Number** refers to the contact's work phone number or extension, if applicable.
 - d. **Email** refers to the contact's work email address.
4. Authorized Official Information
 - a. **Name** of the authorized official that agrees to ensure test results are sent in a secure environment. This name will appear on the test results.
 - b. **Title** of position or role within facility.
 - c. **Phone Number** refers to the authorized official's work phone number or extension, if applicable.
 - d. **Email** refers to the authorized official's work email address.
 - e. **Authorized Official Signature** must be signed digitally via Adobe Sign or signed with black or blue ink.
 - f. **Date** refers to the date the client agreement has been signed.