



San Diego County Fire Protection District

Underground Piping for Private Hydrants & Sprinkler Supply Line

PURPOSE

The provision of adequate water supplies and distribution systems for fire suppression is a fundamental component of risk reduction. The purpose of this guideline is to provide the basic information necessary to meet minimum requirements for the design and installation of private hydrant and/or sprinkler supply underground piping in accordance with the provisions of the latest adopted version of the California Fire Code (CFC), the California Building Code (CBC), and the latest adopted editions of NFPA 24, NFPA 13, NFPA 13R referenced in Chapter 80 of the CFC, and locally adopted amendments to these codes.

SCOPE

This guideline is applicable to all private underground piping for hydrants and/or sprinkler supply lines within the jurisdiction of the San Diego County Fire Protection District. This guideline is not applicable to underground piping serving fire sprinkler systems designed in accordance with the latest adopted editions of NFPA 13D and some systems designed in accordance with the latest adopted editions NFPA 13R.

SUBMITTAL REQUIREMENTS

1. General

A. Plans for all private underground piping for private hydrants and/or sprinkler supply line(s) shall be submitted to SDCFPD for review and approval prior to installation.

B. All new plan submittals and revisions will consist of **3** hard copies. Verify plan submittal requirements with the Building Department prior to submitting.

C. Plans shall be legible, scaled to nationally recognized standards, and printed as a blue or blackline drawing. The SDCFPD does not accept either pen and ink plans or pen & ink changes to blue-line plans.

2. Information to be provided on the title page

A. Applicable codes and standards used for the system design (e.g., current adopted versions of the CFC, CBC, NFPA 24, etc.).

B. Project location, including the full legal address of the facility, and building number(s) if applicable; tract or parcel number, and permit number.

C. The contractor's name, telephone number, address, and California State contractor's license number and classification. Contractors must possess a valid A, C16, or C34 license or be registered as a (Fire Protection)Professional Engineer (PE). *Note: If the piping plan is designed by a PE, the plan shall contain the name, license number, and classification of the installing contractor, along with the PE wet stamp.*

**** All commercial Fire Protection systems must be stamped by a California Licensed Fire Protection Engineer.**

3. Additional Required Information

A. Location of public mains and all public hydrants within 400 feet of the site.



San Diego County Fire Protection District

Underground Piping for Private Hydrants & Sprinkler Supply Line

B. Location of all valves. Specify the type for each (e.g., post indicator valve (PIV), key gate valve, system control valve, double detector check (DDC) assembly, outside stem and yoke (OS&Y), etc.).

C. PIVs, or other approved indicating valves, serving buildings 40 feet or more in height shall be located a minimum of 40 feet from the building. For buildings less than 40 feet tall, the valve shall be located no closer than the height of the building. Where it is *impractical* to locate control valve(s) at these minimum distances, they may be located closer using one of the following methods:

- 1) Approved wall mount indicating valves: Located on exterior walls without openings within 15 feet of the valve(s).
- 2) Valve room or exit stair enclosure: When the valve is placed in a room separated from the building by a minimum one-hour fire barrier, and the room is accessible from outside.
- 3) Exterior risers: The valve may be placed in locations adjacent to exterior walls without openings within 15 feet of the valve.
- 4) An approved manner acceptable to SDCFPD.

D. Pipe size, class, and type; specify lined or unlined if applicable.

E. Indicate that ferrous pipe and fittings (excluding stainless steel 316) shall be encased in loose-fitting polyethylene *tubing* (pipe shall not be wrapped in polyethylene sheets) and that ferrous joints, pipe, and fittings shall be coated with asphaltic sealant or equivalent to inhibit corrosion. Exposed edges, cuts, and tears shall be tightly taped to inhibit water infiltration. Where joints are present in tubing, a minimum one-foot overlap shall be provided. Tubing shall extend 3 feet beyond transition between areas where ferrous pipe or fittings are used and where non-ferrous pipe begins.

F. Thrust block locations or specify the means of restraint as approved by the current adopted edition of NFPA 24, San Diego County Water Agencies Standards, and CFA#501.

G. Provide a fire riser detail. When a pipe runs under footings or foundations of the building, a single corrosion resistant stainless steel pipe unit assembly is required. The pipe shall terminate a maximum of 24 inches from the exterior wall and a minimum of 6 inches above the finished floor. A minimum of 2 inches clearance (annular space) shall be provided where the pipe passes through the floor or wall.

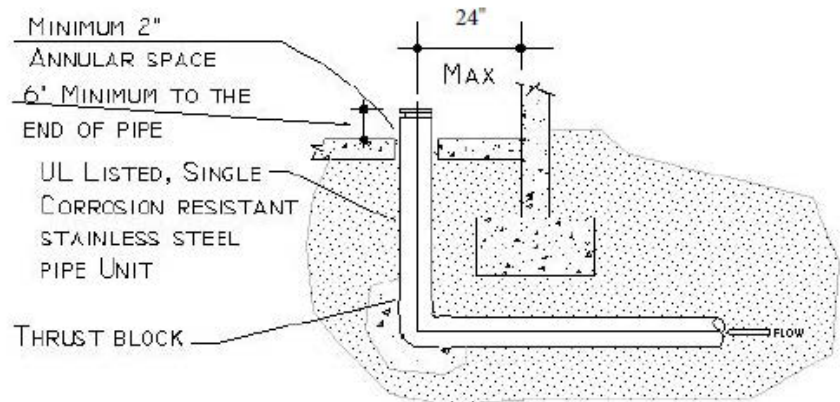

UNDER FOUNDATION
RISER DETAIL (N.T.S.)



San Diego County Fire Protection District

Underground Piping for Private Hydrants & Sprinkler Supply Line

H. Provide a typical trench detail/section showing the depth of bury and thickness of sand bedding above and below the pipe.

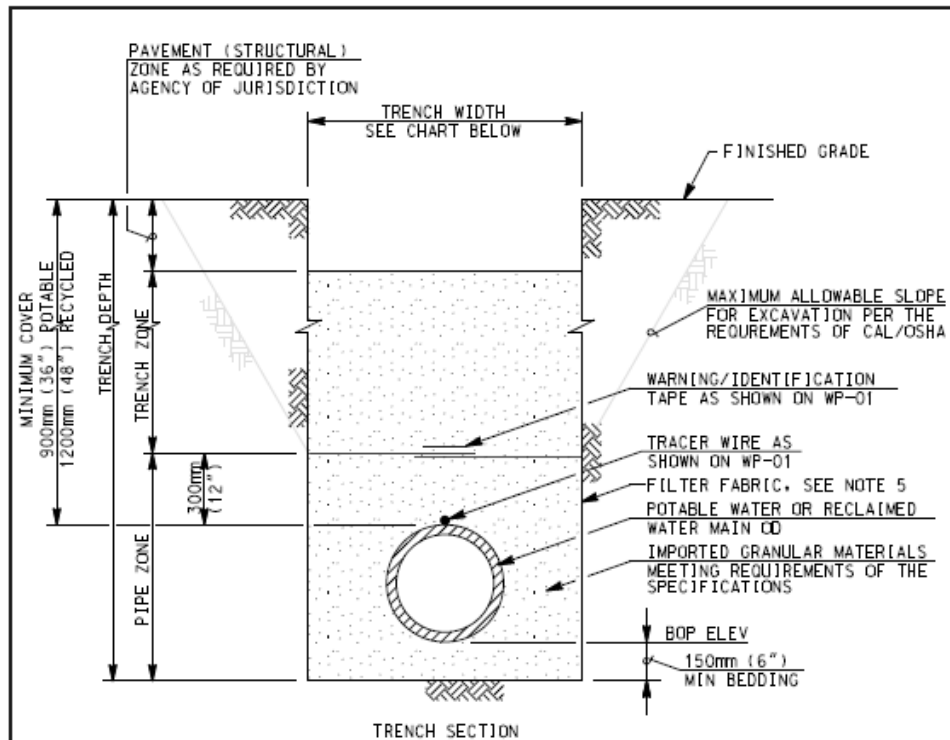

NOTES:

- 1) REFER TO SECTION 02223 OF THE SPECIFICATIONS
- 2) PAVING OR PAVEMENT REPAIR TO BE DONE IN ACCORDINANCE TO CITY OR COUNTY STANDARDS
- 3) EXCAVATE BELL HOLES AT EACH PIPE JOINT TO PERMIT PROPER ASSEMBLY AND INSPECTION OF THE ENTIRE JOINT
- 4) ALL PIPELINE TRENCHES SHALL BE EXCAVATED SO THAT THE DISTANCE BETWEEN TRENCH WALLS AT THE TOP OF PIPE SHALL BE AS SHOWN BELOW:

TRENCH WIDTH		
NOMINAL PIPE (INSIDE DIAMETER)	MINIMUM DISTANCE	MAXIMUM DISTANCE
100mm (4") & SMALLER	450mm (18")	700mm (28")
150mm & 200mm (6" & 8")	600mm (24")	800mm (32")
250mm & 300mm (10" & 12")	700mm (28")	900mm (36")
400mm THRU 900mm (16" THRU 36")	OD PLUS 600mm (24")	OD PLUS 900mm (36")

- 5) FILTER FABRIC (BURRITO WRAP) AS REQUIRED IN SECTION 02223 OF THE SPECIFICATIONS WITH A MINIMUM 300mm (12") OVERLAP
- 6) FOR BEDDING AND BACKFILL OF SEWER FACILITIES SEE SP-02

PIPE BEDDING AND TRENCH BACKFILL FOR POTABLE AND RECYCLED WATER

WATER AGENCIES STANDARDS
 COMMITTEE APPROVAL: 08/03/2018
 DRAWING NUMBER: WP-02



San Diego County Fire Protection District

Underground Piping for Private Hydrants & Sprinkler Supply Line

I. The attached “**SAN DIEGO COUNTY FIRE PROTECTION DISTRICT NOTES FOR UNDERGROUND PIPING FOR PRIVATE HYDRANTS AND SPRINKLERS**” shall be placed, verbatim, on all underground plans.

J. The attached “**SAN DIEGO COUNTY FIRE PROTECTION DISTRICT NOTES FOR THRUST BLOCK RESTRAINTS**” shall be placed on all underground plans that use thrust blocks as the restraining method.

4. Underground Service for NFPA 13R Systems

Underground service shall comply with one of the following designs based upon the parameters described:

- A. The system design shall comply with NFPA 13 and NFPA 24 (see Sections 1 through 3 above) when:
 - 1) Serving more than one R-1, R-2, or R-4 occupancy, or
 - 2) The FDC is located between the city supply and sprinkler riser check valve.
- B. The system design shall comply with NFPA 13R and the California Plumbing Code (CPC) when:
 - 1) Serving a single R-1, R-2, or R-4 occupancy, and
 - 2) The FDC is located downstream of (i.e., after) the sprinkler system riser check valve. The underground system may be interconnected with the building’s domestic water supply line or may be a dedicated fire line. The FDC shall also comply with relevant requirements listed in this guideline including, but not limited to, identification, painting, accessibility, and orientation.

5. Additional Requirements

A. All bolts used for underground connections, including T bolts, shall be 316 stainless steel. Asphaltic sealants (and other opaque sealants) shall not be used to coat bolts (this is to ensure bolts can still be verified as 316 stainless steel during inspection).

B. FDC's shall be on the address side of the building and located immediately adjacent to the approved fire department access road. The FDC shall be in a position allowing hose lines to be readily and conveniently attached. The FDC shall contain a minimum of *two* 2½ inch inlets. When the sprinkler demand is 500 gpm or greater (including the interior hose stream demand) or a standpipe system is included, *four* 2½ inch inlets shall be provided. The FDC shall be a listed assembly, i.e. Potter-Roemer FDC Models 5761-5764, 5775, 5776, 5780, 5781, 5785, 5786, Guardian FDC Models 6224, 6226, 6242, 6244, or similar listed devices. *Note: These are just examples of the models that would be accepted by SDCFPD. SDCFPD does not endorse any specific manufacturer.*

C. FDCs shall be no more than 100 feet from a public hydrant.

D. FDCs, PIVs, and backflow assemblies shall be readily visible and accessible from the fire lane. Vegetation may be used to screen backflow assemblies on the side that does not face the fire department access roadway.

E. FDCs and PIVs, shall be painted OSHA safety red. The closest upstream indicating valve to the riser shall be painted OSHA safety red.

F. FDCs, PIVs, and DDCs, shall have durable, legible signs clearly indicating the address of the facility they serve or, where appropriate, their function (e.g., “Sectional Valve 1 of 2”). Signs must be metal, secured with a chain or wire, and the letters must be contrasting. Signs shall be securely attached to the device.



San Diego County Fire Protection District

Underground Piping for Private Hydrants & Sprinkler Supply Line

G. Large private fire service mains shall have post indicating type sectional control valves at appropriate points to permit isolation of the system in the event of a break or during repair or extension. *Note: A large system is considered one with more than 6 connections including fire hydrants.*

H. Remote FDC's in Industrial /Commercial complexes may be required by SDCFPD.

PLACE THE FOLLOWING NOTES, VERBATIM, ON THE PLAN:

SAN DIEGO COUNTY FIRE PROTECTION DISTRICT NOTES FOR UNDERGROUND PIPING FOR PRIVATE HYDRANTS & SPRINKLERS

INSPECTION REQUIREMENTS

1. A minimum of three SDCFPD inspections are required for underground piping serving sprinkler systems and/or private hydrants: 1) Pre-pour inspection; 2) Hydrostatic testing; 3) Flush inspection. Please schedule all inspections at least 48 hours in advance. Call SDCFPD at (858) 974-5999 or the Battalion fire prevention specialist.
2. Pre-pour inspection: Thrust block excavation shall be completed, but thrust blocks shall not be poured. All pipe shall be in place and exposed for visual inspection. Pipe shall be laid on a minimum 6 inch bed of clean sand. Trenches shall be of a sufficient depth to allow the required cover above the pipe. Ferrous pipe and fittings shall be encased in polyethylene tubing (not wrapped) and tightly taped to inhibit soil infiltration. Ferrous joints (except for stainless steel 316) shall be coated with asphaltic sealant or other corrosion retarding material.
3. Hydro Testing: Thrust blocks shall be in place. Pipe shall be center loaded with clean sand to prevent uplift, but all joints shall remain exposed. The system shall be hydrostatically tested at 200 psi (Or 50 psi over maximum static pressure, whichever is greater) for a duration of at least 2 hours prior to the arrival of the SDCFPD inspector. See item 15 for detailed requirements.
4. Flush inspection: All portions of the underground system shall be flushed to remove debris prior to connection to overhead piping. Flow shall be through a minimum of a four-inch hose or pipe, unless otherwise approved by the SDCFPD inspector prior to scheduling the flush. Hose or pipe shall be restrained to prevent injury and damage. Discharged water shall be collected or diverted in accordance with applicable SWPPP/NPDES provisions. The local public works department, water district, and/or other applicable agency shall be notified of the scheduled flush by the contractor. The SDCFPD flush and hydro inspections may be scheduled concurrently.
5. Flushing requirements shall follow NFPA 24, where underground piping serves a fire pump, the requirements of NFPA 20 shall be followed.
6. Upon flush inspection or prior to final sprinkler or site inspection, all detector check assemblies, CFA #500



San Diego County Fire Protection District

Underground Piping for Private Hydrants & Sprinkler Supply Line

control valves, and fire department connections (FDC) shall be clearly labeled with the address(es) served by the device. Address signs shall be securely attached to the device and be of a durable, fade-resistant material which is visible and legible from the fire lane. FDC and 4-inch hydrant outlets shall be unobstructed and oriented toward the fire lane. Valves shall be locked in the open position with breakaway locks. All PIV valves and private hydrants shall be painted OSHA safety red.

7. The closest upstream indicating valve to the riser shall be painted OSHA safety red. Hydrant and FDC caps shall be in place.

GENERAL REQUIREMENTS

8. Installation, inspection, and testing shall conform to current adopted editions of NFPA 13 and NFPA 24. SDCFPD jurisdiction begins at the downstream side of the last valve on the detector check assembly. Verify design and installation requirements for the portion of the system preceding this point with the local water district.

9. Vegetation shall be selected and maintained in such a manner as to allow immediate location of, and unobstructed access to; all hydrants, control valves, fire department connections, and other devices or areas used for firefighting purposes.

10. A minimum 3-foot clearance shall be provided around all hydrants and post indicating valves. A minimum 3-foot clearance shall be provided on at least one side of a detector check assembly to allow proper operation of the device. The front of the FDC and the adjacent fire access roadway shall be free of any obstructions.

11. Any future modification to the approved private underground piping system is subject to review, inspection, and approval by the SDCFPD.

12. Approval of this plan shall not be interpreted as approval of any information or project conditions other than those items and requirements identified in SDCFPD Underground Developers Guide CFA #500, and applicable sections of the current adopted editions of NFPA 13 and NFPA 24. This project may be subject to additional requirements not stated herein upon examination of actual site and project conditions or disclosure of additional information.

PIPE AND TRENCH REQUIREMENTS

13. A 6-inch bed of clean fill sand shall be provided below the pipe and 12 inches above the pipe (total of 18 inches plus outer diameter of the pipe).

14. Pipe shall be buried at least 36 inches where subject to loading (e.g., driveways, parking lots) and at least 30 inches elsewhere.

15. All pipe shall be approved for use in fire service systems. Class 150 will be used at a minimum, and class 200 pipe shall be used where the water pressure exceeds 150 psi. The use of galvanized pipe is prohibited when a portion of the system is buried.



San Diego County Fire Protection District

Underground Piping for Private Hydrants & Sprinkler Supply Line

16. All ferrous pipe and fittings shall be protected with a loose 8-mil polyethylene tube. Wrapping the pipe in polyethylene sheeting is not acceptable. The ends of the tube and any splices made for tees or other piping components shall be tightly sealed with 2-inch tape that is approved for underground use.
17. All bolts used for underground connections, including T bolts, shall be 316 stainless steel. Asphaltic sealants (and other opaque sealants) shall not be used to coat bolts (this is to ensure bolts can still be verified as 316 stainless steel during inspection). All ferrous fittings (except for 316 stainless steel) shall be cleaned and thoroughly coated with asphalt or other corrosion retarding material after assembly and prior to the installation of polyethylene tube.
18. Thrust blocks, or another approved method of thrust restraint, shall be provided wherever pipe changes direction.
19. A minimum 2-inch clearance shall be provided where the pipe passes through slabs or walls. Underground system shall terminate at the riser flange and placed a maximum of 24 inches from an exterior wall and 6 inches above the slab.
20. The FDC shall contain a minimum of two 2 ½ inch inlets when the system design demand, including the interior hose stream demand or a standpipe, is a minimum 250 gpm. When the system design demand, including the interior hose stream demand or a standpipe, is a minimum 500 gpm, four 2 ½ inch inlets shall be provided. FDCs shall be painted OSHA safety red.
21. Pipe running under a building or building foundation shall be stainless steel and shall not contain mechanical joints.
22. Installation of Underground piping shall follow manufacturers specifications & installation guidelines.

HYDRANT REQUIREMENTS

23. Private fire hydrants shall be listed with a minimum of one 2 ½ inch and one 4-inch outlet. The 4-inch outlet shall face the fire department access road. All outlets shall be provided with National Standard Threads (NST). Private hydrants shall be painted OSHA safety red.
24. Fire hydrant supply piping shall be a minimum of 6 inches in diameter. The lowest valve operating nut shall be a minimum of 18 inches above grade and the hydrant flange shall be a minimum of 2 inches above grade.
25. A keyed gate valve shall be provided for each hydrant in an accessible location. Keyed gate valves shall be located within 10 feet of the hydrant in an area that is unobstructed and clearly visible. Valves shall not be in parking stalls.
26. All fire hydrants shall have a “Blue Reflective Pavement Marker” indicating their location. Private hydrants and markers are to be maintained in good condition by the property owner.



San Diego County Fire Protection District
Underground Piping for Private Hydrants & Sprinkler Supply Line

PLACE THE FOLLOWING NOTES / INFORMATION ON THE PLAN:

SAN DIEGO COUNTY FIRE PROTECTION DISTRICT
NOTES FOR THRUST BLOCK RESTRAINTS

- Type of Restraint used.
- Results of calculations for all Thrust Blocks and Anchor Blocks shall be individually noted in the plan presented in the form of a clear and complete “Thrust/Anchor Block Table.” Thrust Block and Anchor Block information shall include pipe station, type of block, test pressure, total thrust, assumed or tested soil capacity, and area or volume of block(s) required.
- The most conservative sizing specifications for Thrust Block / Valve supports shall be used. Either Valve support and Thrust/Anchor Block box from regional standards drawings or calculated values will be clearly displayed on plans.
- Applicable diagrams of Thrust / Anchor blocks from Thrust block detail sheet.
- Underneath Thrust/Anchor Block table, print “Concrete used for Thrust Blocks/Anchors to be a minimum of Class 560-C 3250 Concrete unless otherwise directed by the design engineer.”
- Soils information.
- Thrust block bearing faces shall be placed against undisturbed soil, approved compacted backfill, or Class 100-E-100 slurry.
- To facilitate future removal of thrust blocks and line extension use cardboard separators between blocks, if needed.

See Detail sheets for additional information:

- SDCFPD Thrust Block detail CFA #501
- SDCFPD Hydrant pad and bollard detail CFA #502
- SDCFPD Hydrant detail CFA #503
- SDCFPD FDC’s and PIV’s detail CFA #504